

TECHNICAL MANUAL

ORGANIZATIONAL, DIRECT SUPPORT, AND GENERAL SUPPORT MAINTENANCE
REPAIR PARTS AND SPECIAL TOOLS LISTS
(INCLUDING DEPOT MAINTENANCE REPAIR PARTS AND SPECIAL TOOLS)
FOR
MANUAL TELEPHONE SWITCHBOARD SB-86/P
(NSN 5805-00-503-2660)

HEADQUARTERS, DEPARTMENT OF THE ARMY

21 AUGUST 1980

TECHNICAL MANUAL
No. 11-5805-304-24P

HEADQUARTERS
DEPARTMENT OF THE ARMY
WASHINGTON, DC, 21 August 1980

ORGANIZATIONAL, DIRECT SUPPORT, AND GENERAL SUPPORT MAINTENANCE
REPAIR PARTS AND SPECIAL TOOLS LISTS
(INCLUDING DEPOT MAINTENANCE REPAIR PARTS AND
SPECIAL TOOLS)
FOR
MANUAL TELEPHONE SWITCHBOARD SB-86/P
(NSN 5805-00-503-2660)

Current as of 25 February 1980

REPORTING ERRORS AND RECOMMENDING IMPROVEMENTS

You can help improve this manual. If you find any mistakes or if you know of a way to improve the procedures, please let us know. Mail your letter, DA Form 2028 (Recommended Changes to Publications and Blank Forms), or DA Form 2028-2 located in back of this manual direct to: Commander, US Army Communications and Electronics Materiel Readiness Command, ATTN: DRSEL-ME-MQ, Fort Monmouth, NJ 07703. In either case, a reply will be furnished direct to you.

Table of Contents

	Page	Illus Figure
SECTION I. Introduction	1	
II. Repair parts list	5	
GROUP 0 Manual Telephone Switchboard SB-86/P	5	1
01 Log plate assembly (A1)	7	2
02 Cover assembly (A2).....	11	3
0201 Locking rod assembly (A2A1)	13	4
03 Signal assembly switch (A3).....	15	5
Signal assembly switch (A3) cabinet assembly.....	17	6
0301 Chasis assembly (A3A2).....	19	7
Chasis assembly (A3A2), front view and rear view.....	21	8
Chasis assembly (A3A2), and panel assemblies.....	23	9
030101 Jack assembly switch (A3A2A2A1)	25	10
04 Telephone switch section (A4)	27	11
Telephone switch section (A4), and cabinet assembly	29	12
0401 Telephone circuit card (A4A3)	33	13
040101 Reel assembly (A4A3A1A1)	35	14
0402 Operator's telephone circuit (A4A4).....	39	15
040201 Terminal board (A4A4A1).....	43	16
05 Power Supply PP-990/G	47	17
Power Supply PP-990/G, Case Assembly.....	51	18
Power Supply PP-990/G, Chassis Assembly.....	53	19
Power Supply PP-990/G, Inverter Vibrator Assembly.....	55	20
SECTION III. Special tools list (Nonapplicable)		
IV. National stock number and part number index.....	56	

* This manual supersedes TM 11-5805-304-20P, 6 December 1971 and TM 11-5805-304-35P, 5 January 1972.

SECTION I INTRODUCTION

1. Scope

This manual lists spares and repair parts; special tools; special test, measurement, and diagnostic equipment (TMDE), and other special support equipment required for performance of organizational, direct support, and general support maintenance of the SB-86P. It authorizes the requisitioning and issue of spares and repair parts as indicated by the source and maintenance codes.

2. General

This Repair Parts and Special Tools List is divided into the following sections:

a. Section II. Repair Parts List. A list of spares and repair parts authorized for use in the performance of maintenance. The list also includes parts which must be removed for replacement of the authorized parts. Parts lists are composed of functional groups in numeric sequence, with the parts in each group listed in figure and item number sequence.

b. Section III. Special Tools List. Not applicable.

c. Section IV. National Stock Number and Part Number Index. A list, in National item identification number (NIIN) sequence, of all National stock numbers (NSN) appearing in the listings, followed by a list, in alphameric sequence, of all part numbers appearing in the listings. National stock numbers and part numbers are cross-referenced to each illustration figure and item number appearance.

3. Explanation of Columns

a. Illustration. This column is divided as follows :

(1) *Figure number.* Indicates the figure number of the illustration on which the item is shown.

(2) *Item number.* The number used to identify item called out in the illustration.

b. Source, Maintenance, and Recoverability (SMR) Codes.

(1) *Source code.* Source codes indicate the manner of acquiring support items for maintenance, repair, or overhaul of end items. Source codes are entered in the first and second positions of the Uniform SMR Code format as follows:

<i>Code</i>	<i>Definition</i>
PA-Item	procured and stocked for anticipated or known usage.

XD-A support item that is not stocked. When required, item will be procured through normal supply channels.

NOTE

Cannibalization or salvage may be used as a source of supply for any items source coded above except those coded XA and aircraft support items as restricted by AR 700-42.

(2) *Maintenance code.* Maintenance codes are assigned to indicate the levels of maintenance authorized to USE and REPAIR support items. The maintenance codes are entered in the third and fourth positions of the Uniform SMR Code format as follows:

(a) The maintenance code entered in the third position will indicate the lowest maintenance level authorized to remove, replace, and use the support item. The maintenance code entered in the fourth position will indicate one of the following levels of maintenance:

<i>Code</i>	<i>Application/Explanation</i>
O-Support	item is removed, replaced, used at the organizational level.

F-Support item is removed, replaced, used at the direct support level.

(b) The maintenance code entered in the fourth position indicates whether the item is to be repaired and identifies the lowest maintenance level with the capability to perform complete repair (i.e., all authorized maintenance functions).

This position will contain one of the following maintenance codes:

- | <i>Code</i> | <i>Application/Explanation</i> |
|-------------|--|
| F | The lowest maintenance level capable of complete repair of the support item is the direct support level. |
| D | The lowest maintenance level capable of complete repair of the support item is the depot level. |
| Z | Nonreparable. No repair is authorized. |

(3) *Recoverability code.* Recoverability codes are assigned to support items to indicate the disposition action on unserviceable items. The recoverability code is entered in the fifth position of the Uniform SMR Code format as follows:

- | <i>Recoverability codes</i> | <i>Definition</i> |
|-----------------------------|--|
| Z | Nonreparable item. When unserviceable, condemn and dispose at the level indicated in position 3. |
| F | Reparable item. When uneconomically repairable, condemn and dispose at the direct support level. |
| L | Reparable item. Repair, condemnation, and disposal not authorized below depot/specialized repair activity level. |

c. National Stock Number. Indicates the National stock number assigned to the item and will be used for requisitioning purposes.

d. Part Number. Indicates the primary number used by the manufacturer (individual, company, firm, corporation, or Government activity), which controls the design and characteristics of the item by means of its engineering drawings, specifications, standards, and inspection requirements to identify an item or range of items.

NOTE

When a stock numbered item is requisitioned, the repair part received may have a different part number than the part being replaced.

e. Federal Supply Code for Manufacturer (FSCM). The FSCM is a 5-digit numeric code listed in SB 708-42 which is used to identify

the manufacturer, distributor, or Government agency, etc.

f. Description. Indicates the Federal item name and, if required, a minimum description to identify the item.

g. Unit of Measure (U/M). Indicates the standard of the basic quantity of the listed item as used in performing the actual maintenance function. This measure is expressed by a two-character alphabetical abbreviation (e.g., ea, in, pr, etc). When the unit of measure differs from the unit of issue, the lowest unit of issue that will satisfy the required units of measure will be requisitioned.

h. Quantity Incorporated in Unit. Indicates the quantity of the item used in the breakout shown on the illustration figure, which is prepared for a functional group, subfunctional group, or an assembly.

4. Special Information

The following publication pertains to the SB-86/P and its components:

TM 11-2134, Manual Telephone Switchboard SB-86/P.

5. How to Locate Repair Parts

a. When National stock number or part number is unknown.

(1) *First.* Using the table of contents, determine the functional group within which the item belongs. This is necessary since illustrations are prepared for functional groups and listings are divided into the same groups.

(2) *Second.* Find the illustration covering the functional group to which the item belongs.

(3) *Third.* Identify the item on the illustration and note the illustration figure and item number of the item.

(4) *Fourth.* Using the Repair Parts Listing, find the figure and item number noted on the illustration.

b. When National stock number or part number is known.

(1) *First.* Using the Index of National Stock Numbers and Part Numbers, find the pertinent

National stock number or part number. This index is in NIIN sequence followed by a list of part numbers in alphameric sequence, cross-referenced to the illustration figure number and item number.

(2) *Second.* After finding the figure and item

number, locate the figure and item number in the repair parts list.

6. Abbreviations

Not applicable.

(Next printed page is 4)

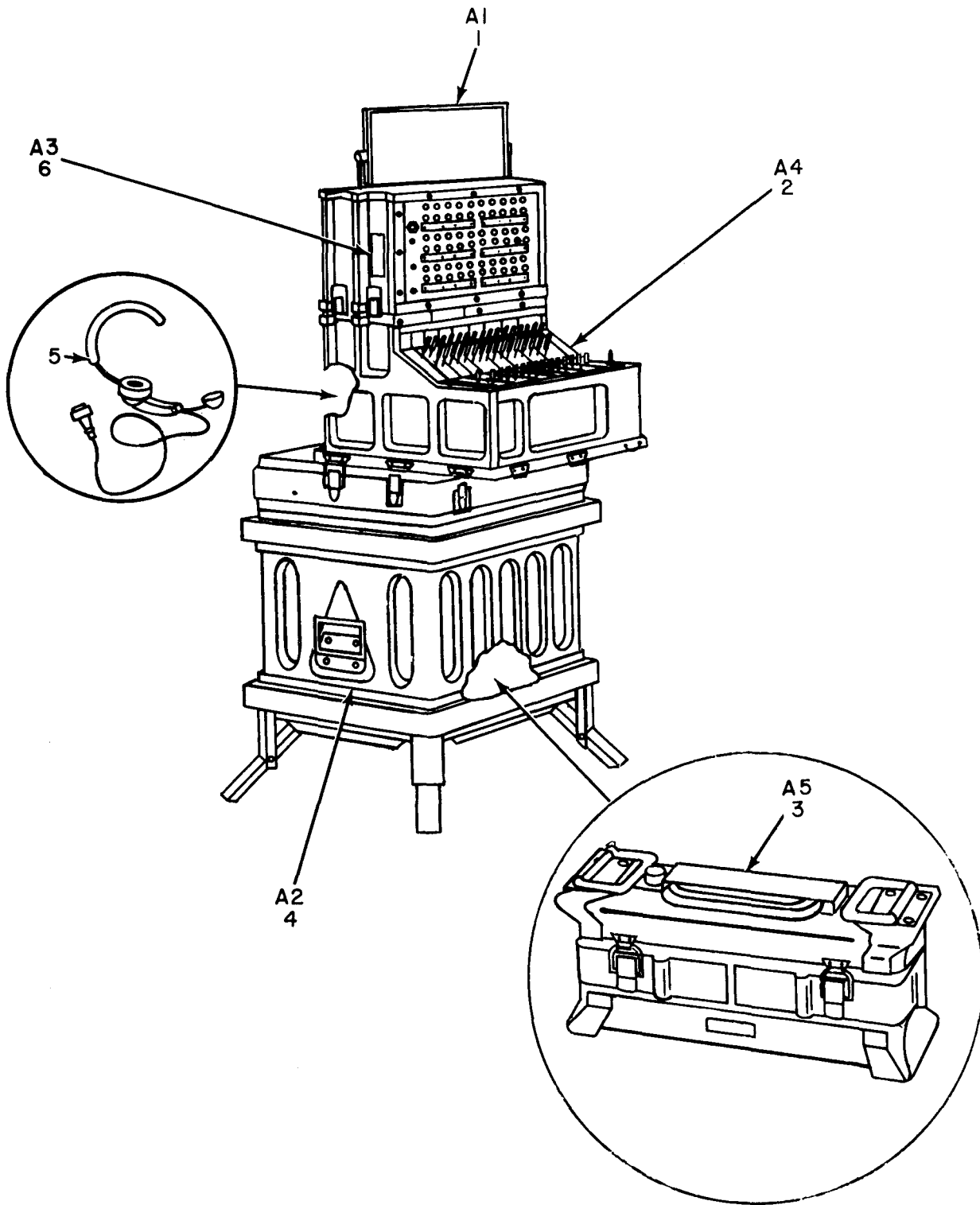

ELOIS001

Figure 1. Manual Telephone Switchboard SB-86/P.

SECTION II

TM11-5805-304-24P

(1)	(2)	(3)	(4)	(5)	(6)	(7)	(8)	
ILLUSTRATION							QTY	
(a)	(b)	NATIONAL			DESCRIPTION		INC	
FIG	ITEM	SMR	STOCK	PART			IN	
NO.	NO.	CODE	NUMBER	NUMBER	FSCM	USABLE ON CODE	U\M	UNIT
GROUP 00 MANUAL TELEPHONE SWITCHBOARD								
SB-86/P								
1	1	XDFFF	5805-00-392-7944	SCC136140	80063	PLATE,LDG	EA 1	
1	2	XDFFF		SB-248/P	80058	TELE SWITCH SECTION	EA 1	
1	3	PAOFF	6130-00-547-1030	PP-990/G	80058	POWER SUPPLY	EA 1	
1	4	PAFFF	5805-00-875-1253	SCD136102	80063	COVER, SWITCHBOARD	EA 1	
1	5	XDFDL		H-91/U	80058	HEADSET-MICROPHONE	EA 1	
1	6	PAOFF	5805-00-503-2616	TA207P	80058	SIGNAL ASSY SWITCH	EA 1	

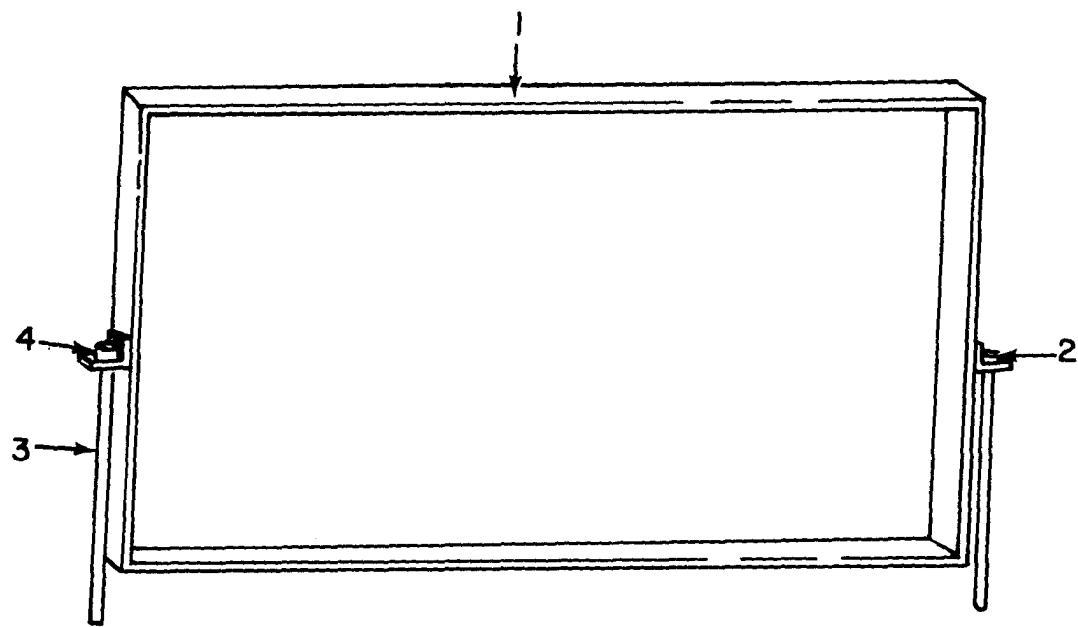

ELOIS002

Figure 2. Log Plate Assembly (A1).

(1)	(2)	(3)	(4)	(5)	(6)	(7)	(8)	
ILLUSTRATION							QTY	
(a)	(b)		NATIONAL		DESCRIPTION		INC	
FIG	ITEM	SMR	STOCK	PART			IN	
NO.	NO.	CODE	NUMBER	NUMBER	FSCM	USABLE ON CODE	U\M	UNIT
GROUP 01 LOG PLATE ASSEMBLY (A1)								
2	1	XDFZZ	SCB136144	80063	PLATE		EA	1
2	2	XDFZZ	SCB136144	80063	BRACKET,MOUNTING		EA	2
2	3	XDFZZ	SCB136142	80063	POST		EA	2
2	4	XDFZZ	SCB136143	80063	KNOB		EA	2

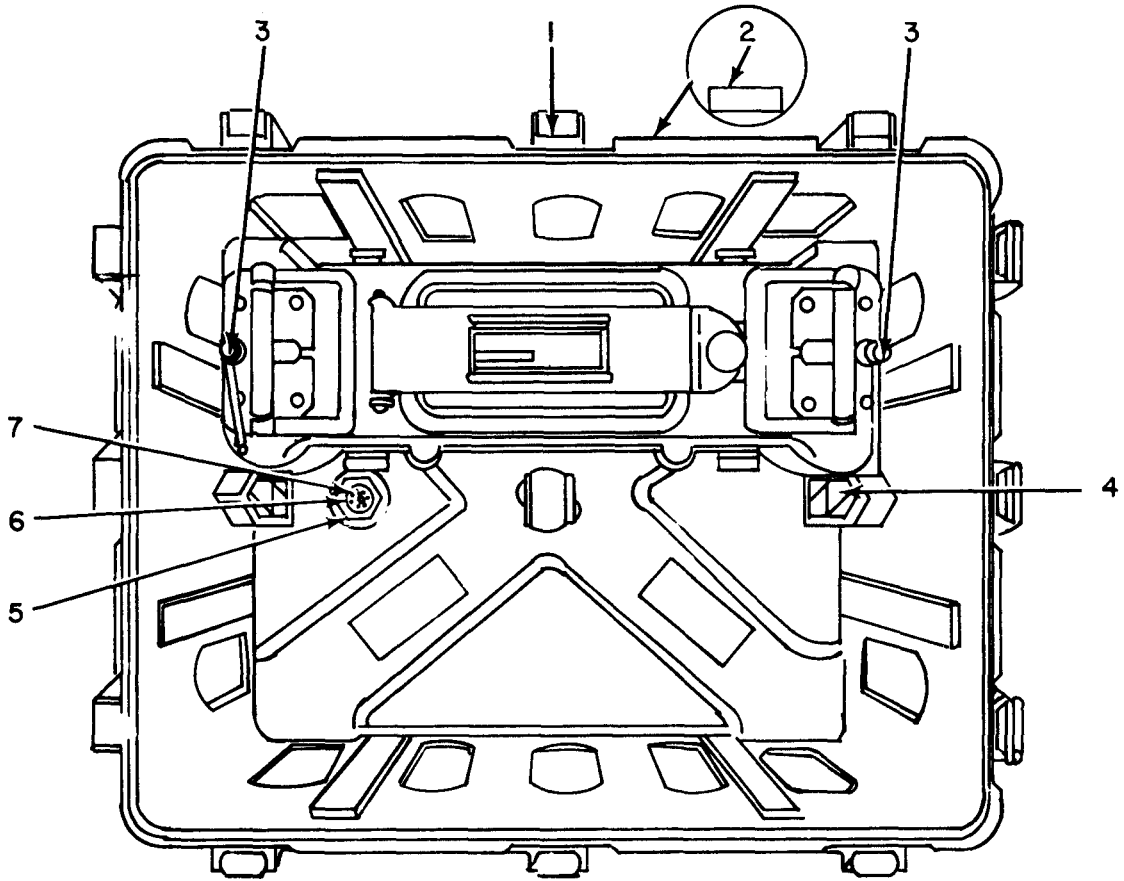

TOP VIEW

ELOIS003

Figure 3. Cover Assembly (A2) (Sheet 1 of 2).

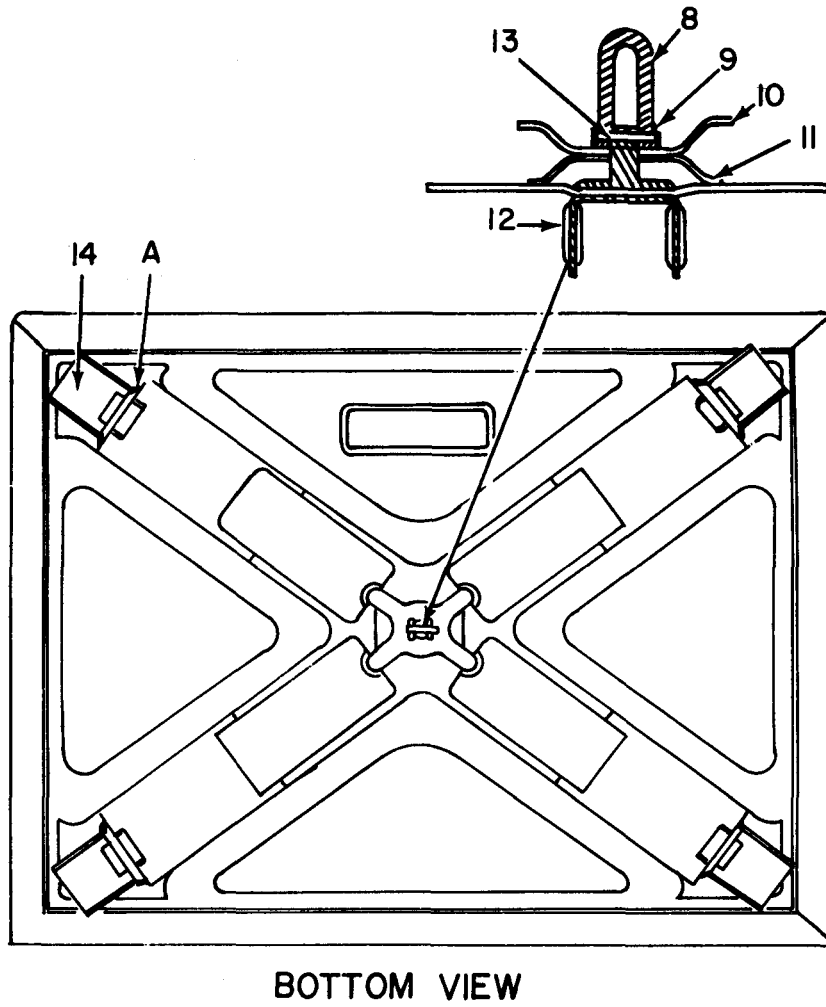

BOTTOM VIEW

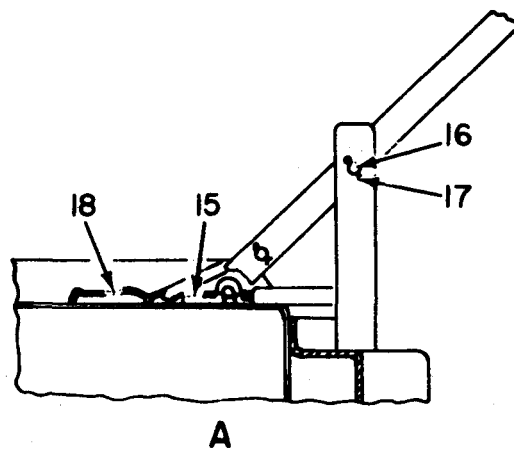

A

ELOIS004

Figure 3. Cover Assembly (A2) (Sheet 2 of 2).

(1) ILLUSTRATION (a) FIG NO.	(2) (b) ITEM NO.	(3) SMR CODE	(3) NATIONAL STOCK NUMBER	(4) PART NUMBER	(5) FSCM	(6) DESCRIPTION	(7) USABLE ON CODE	(8) QTY INC IN UNIT
GROUP 02 COVER ASSEMBLY (A2)								
3	1	PAFZZ	5340-00-205-5206	SCB136113	80063	CATCH, CLAMPING	EA	12
3	2	XDFZZ		SCB136112	80063	PLATE, INDENT	EA	1
3	3	PAFZZ	5805-00-670-5928	SCC136136	80063	ROD, LOCKING ASSEMBL	EA	2
3	4	PAFZZ	5805-00-096-7434	SCB136146	80063	SPRING	EA	2
3	5	XDFZZ	4820-00-142-3142	P519	91816	VALVE, VACUUM BREAKI	EA	1
3	6	XDFZZ		SCB136111	80063	NUT, PLAIN, HEXAGON	EA	1
3	7	PAFZZ	5330-00-198-6177	1820-21	81168	PACKING, PREFORMED	EA	1
3	8	XDFZZ	5805-00-392-7941	SCB136109	80063	CAM	EA	1
3	9	XDFZZ		SCD136102-6	80063	PIN, COTTER	EA	1
3	10	XDFZZ		SCB136108	80063	CLAMP	EA	1
3	11	PAFZZ	5805-00-392-7954	SCB136107	80063	SPRING	EA	1
3	12	XDFZZ		209	74310	GROMMET, RUBBER	EA	2
3	13	PAFZZ	5315-00-200-8367	SCB136104	80063	PIN, STRAIGHT, HEADED	EA	1
3	14	PAFZZ	5805-00-503-3403	SCC136132	80063	LEG, ELECTRICAL EQUI	EA	1
3	15	XDFZZ	5805-00-392-8585	SCB136105	80063	RETAINER, SPRING	EA	4
3	16	XDFZZ		SCB136103-2	80063	PIN, STRAIGHT HLDS	EA	4
3	17	XDFZZ		SCD136102-7	80063	PIN, COTTER	EA	8
3	18	PAFZZ	5805-00-392-7955	SCB136106	80063	SPRING	EA	4

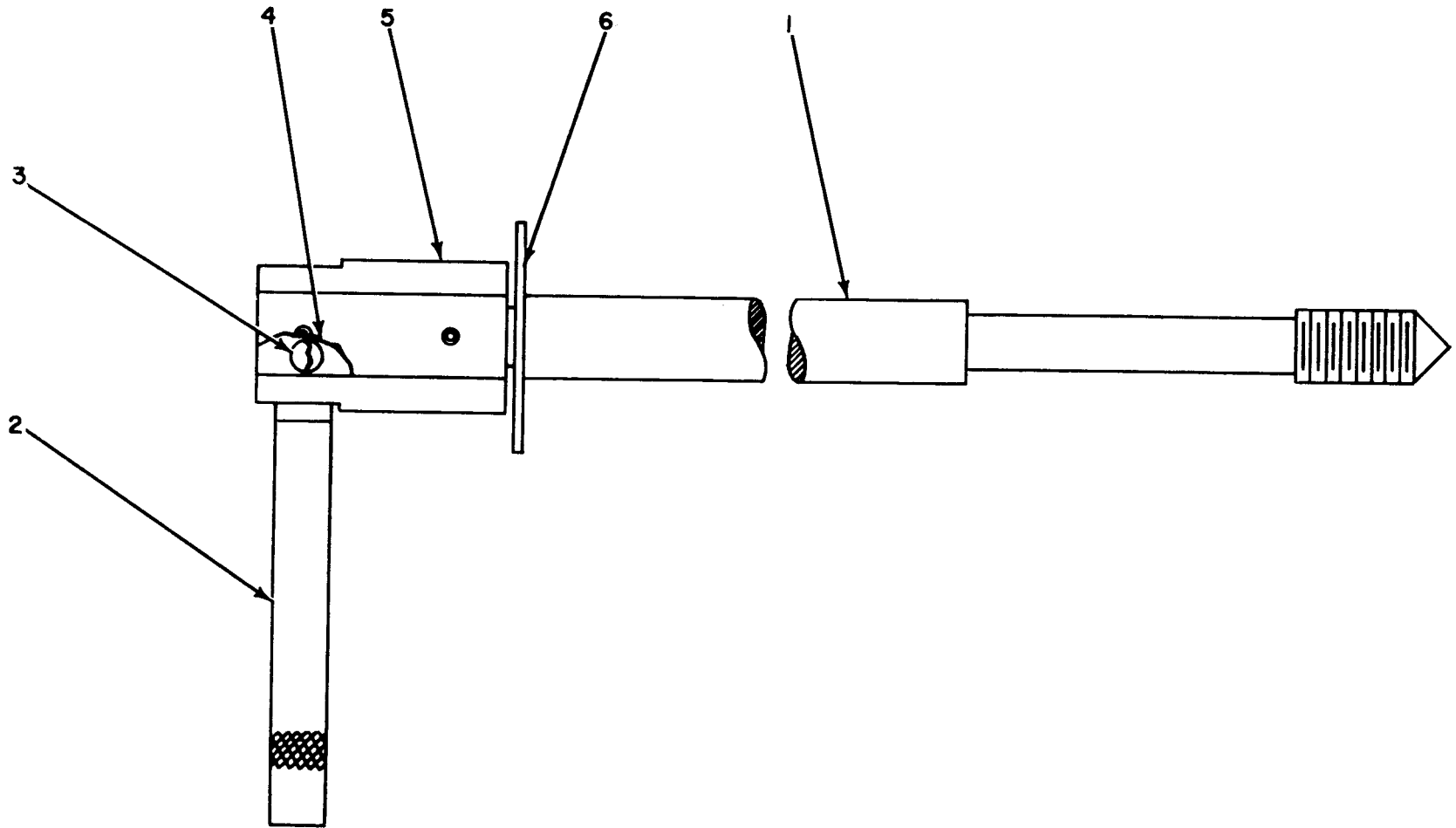
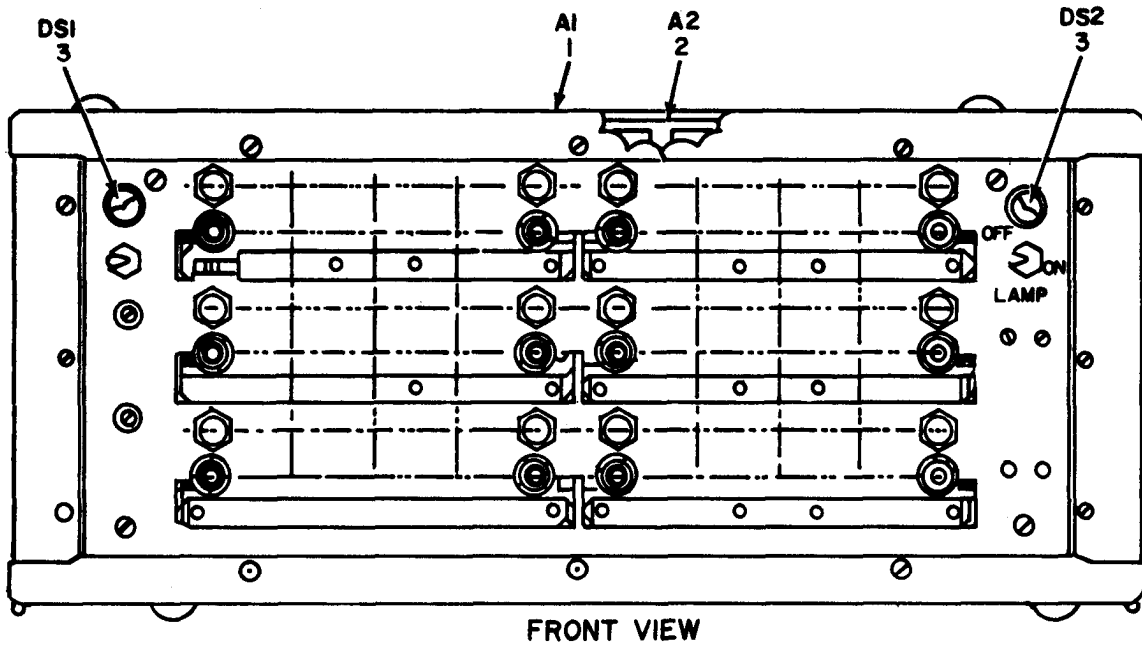
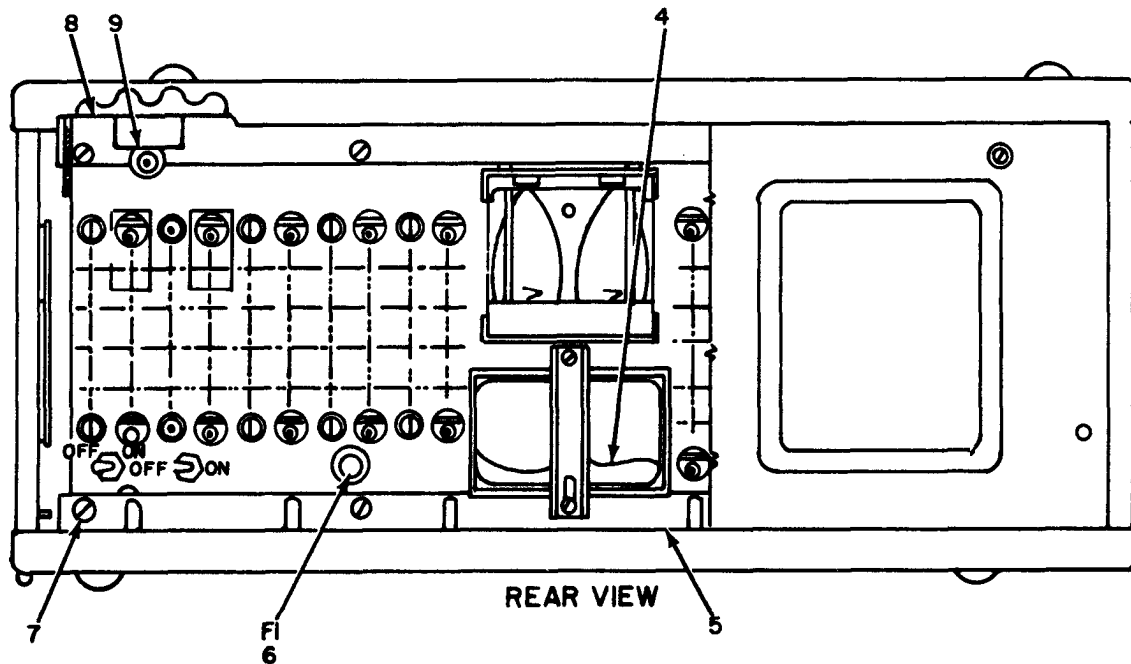

Figure 4. Locking Rod Assembly (A2A1).

(1)	(2)	(3)	(4)	(5)	(6)	(7)	(8)
ILLUSTRATION							
(a)	(b)		NATIONAL		DESCRIPTION		QTY
FIG	ITEM	SMR	STOCK	PART			INC
NO.	NO.	CODE	NUMBER	NUMBER	FSCM	USABLE ON CODE	U/M
							UNIT
GROUP 0201 LOCKING ROD ASSEMBLY (A2A1)							
4	1	XDFZZ	SCC136137	80063	ROD		EA 2
4	2	XDFZZ	SCB136139	80063	PIN		EA 2
4	3	XDFZZ	SCB136148	80063	SPRING,HLCPS		EA 2
4	4	XDFZZ	SCC136136-1	80063	BALL,BEARING		EA 2
4	5	XDFZZ	SCB136138	80063	KNOB		EA 2
4	6	XDFZZ	SCC136136-2	80063	WASHER,FLAT		EA 2



FRONT VIEW



REAR VIEW

NOTE: PREFIX ALL REFERENCE DESIGNATIONS WITH A3.

ELOIS006

Figure 5. Signal Assembly Switch (A3).

(1)	(2)	(3)	(4)	(5)	(6)	(7)	(8)
ILLUSTRATION							
(a)	(b)	NATIONAL			DESCRIPTION		QTY
FIG	ITEM	SMR	STOCK	PART			INC
NO.	NO.	CODE	NUMBER	NUMBER	FSCM	USABLE ON CODE	U\M
							UNIT
GROUP 03 SIGNAL ASSEMBLY SWITCH (A3)							
5	1	XDFFF		SCD136402	80063		EA 1
5	2	XDFFF		SCD136427	80063		EA 1
5	3	PAFZZ	6240-00-196-4501	1490	24446		EA 2
5	4	XDFZZ		SCD136401-8	80063		EA 1
5	5	XDFZZ		SCC136420	80063		EA 1
5	6	PAFZZ	5920-00-284-9454	3131-25	60016		EA 1
5	7	PAFZZ	5305-00-416-6297	MS35226-64	96906		EA 8
5	8	XDFFF		SCD136424	80063		EA 1
5	9	XDFZZ		702	71286		EA 2

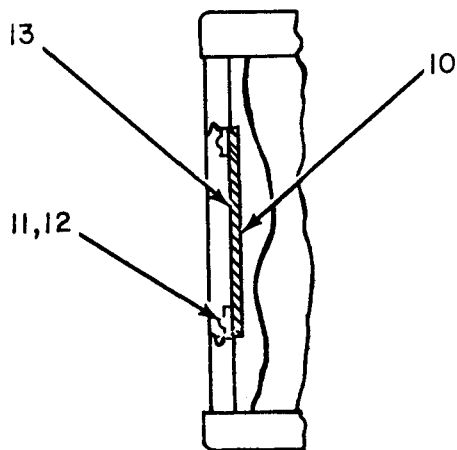
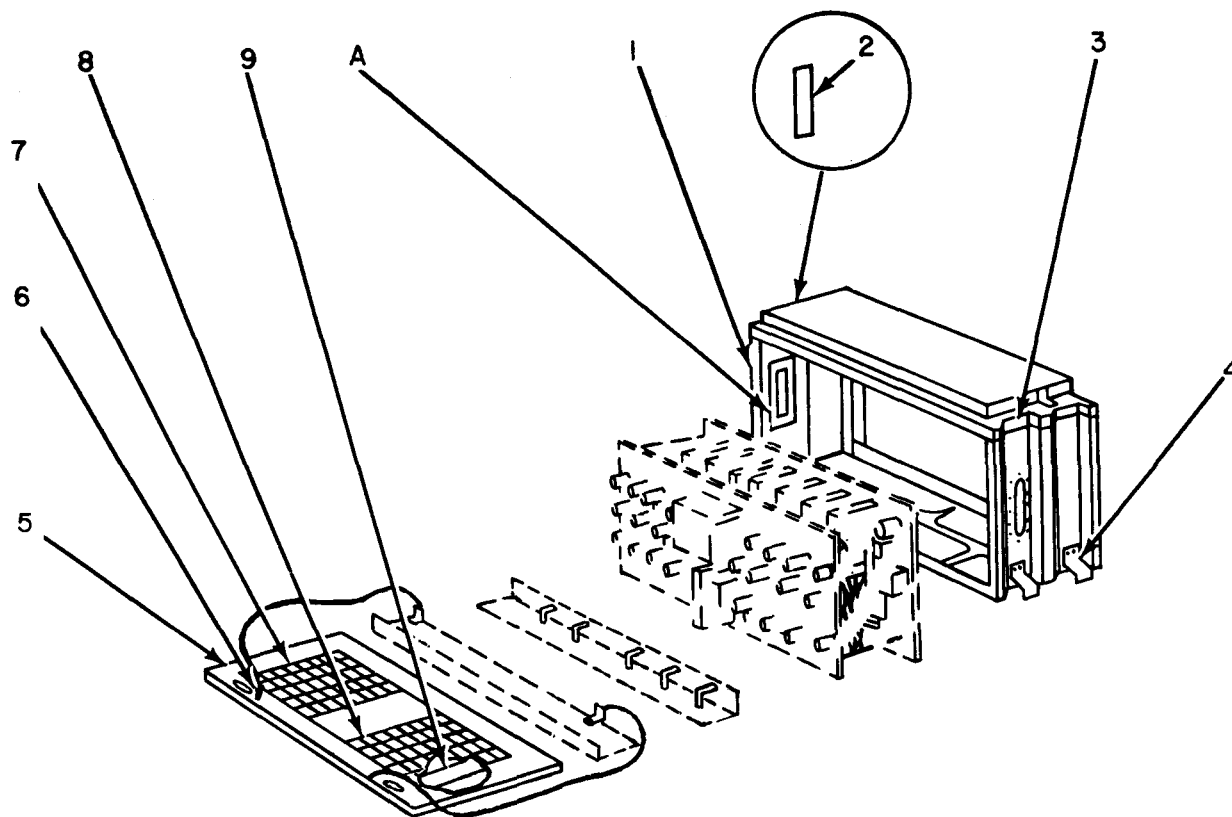

A

ELOIS007

FIGURE 6. Signal Assembly Switch (A3), Cabinet Assembly.

SECTION II

TM11-5805-304-24P

(1) ILLUSTRATION (a) FIG NO.	(2) (b) ITEM NO.	(3) SMR CODE	(4) NATIONAL STOCK NUMBER	(5) PART NUMBER	(6) FSCM	(6) DESCRIPTION	(7) USABLE ON CODE	(8) QTY INC IN UNIT
6	1	XDFFF		SCD136405	80063	CASE ASSEMBLY	EA	1
6	2	XDFZZ		SCB136563	80063	PLATE, IDENT	EA	1
6	3	PAFZZ	5340-00-396-3441	SCB136411	80063	STRIKE, CATCH	EA	4
6	4	XDFZZ		SCB136410	80063	CATCH, BAGGAGE	EA	4
6	5	XDFFF		SCC136412	80063	DOOR ASSEMBLY	EA	1
6	6	PAFZZ	5325-00-285-2017	2600-1	71286	STUD ASSEMBLY, TURN	EA	2
6	7	PAFZZ	5805-00-806-1887	SCC136414	80063	CHART	EA	1
6	8	PAFZZ	9905-00-806-1669	SCC136415	80063	PLATE, DESIGNATION	EA	1
6	9	XDFZZ		SCB136413	80063	BLOCK	EA	2
6	10	XDFZZ		SCB136403	80063	PLATE	EA	2
6	11	XDFZZ		SCD136402-2	80063	SCREW, MACHINE	EA	24
6	12	XDFZZ		SCD136402-3	80063	WASHER, SPLIT	EA	24
6	13	9AFZZ	5330-00-392-5792	SCB136404	80063	GASKET	EA	2

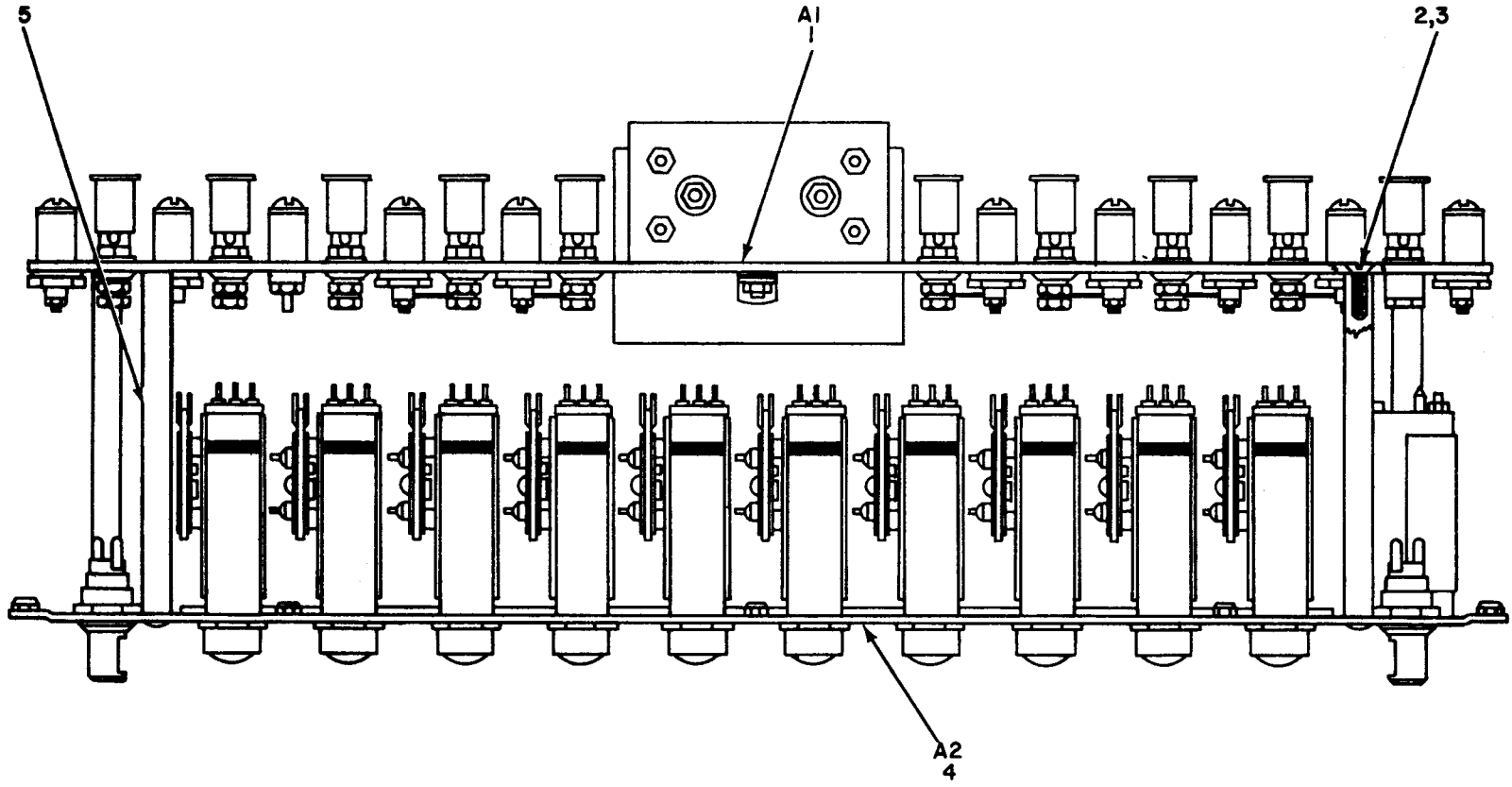

ELOIS008

Figure 7. Chassis Assembly (A3A2).

(1)	(2)	(3)	(4)	(5)	(6)	(7)	(8)	
ILLUSTRATION							QTY	
(a)	(b)		NATIONAL		DESCRIPTION		INC	
FIG	ITEM	SMR	STOCK	PART			IN	
NO.	NO.	CODE	NUMBER	NUMBER	FSCM	USABLE ON CODE	U\M	UNIT
GROUP 0301 CHASSIS ASSEMBLY (A3A2)								
7	1	XDFFF		SCD136429	800623	PANEL ASSEMBLY	EA	1
7	2	PAFZZ	5305-00-984-7363	MS35191-272	96906	SCREW,MACHINE	EA	8
7	3	PAFZZ	5310-00-167-0662	MS35337-43	96906	WASHER	EA	8
7	4	XDFFF		SCD136444	80063	PANEL ASSEMBLY	EA	1
7	5	XDFZZ		SCB136428	80063	POST,SUPPORTING	EA	4

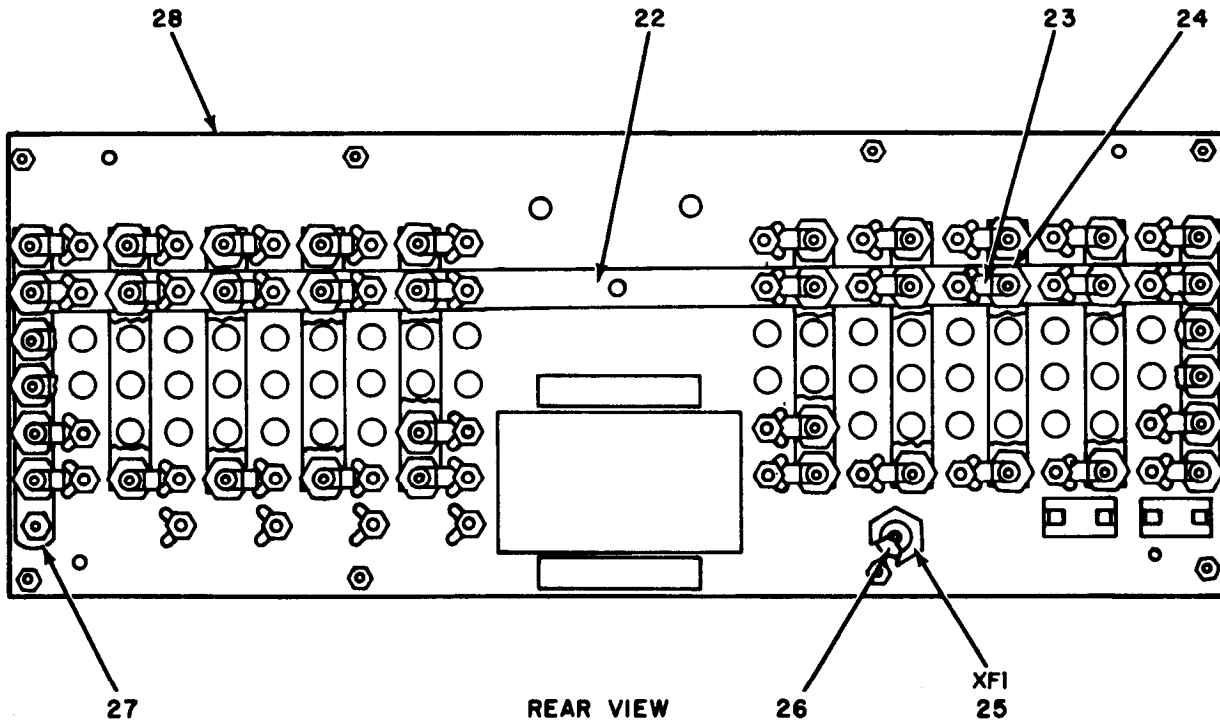
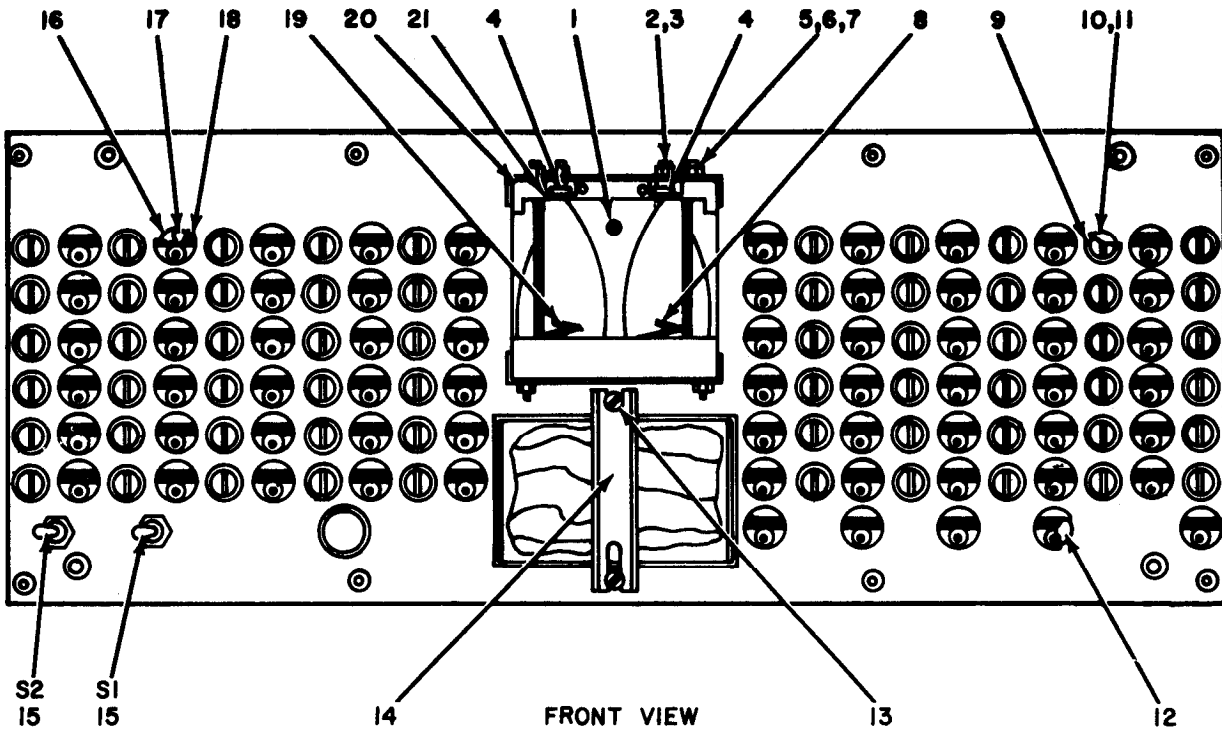

NOTE: PREFIX ALL REFERENCE DESIGNATIONS WITH A3A2AI

ELOIS009

Figure 8. Chassis Assembly (A3A2), Front View and Rear View.

(1) ILLUSTRATION (a) FIG NO.	(2) (b) ITEM NO.	(3) SMR CODE	(4) NATIONAL STOCK NUMBER	(5) PART NUMBER	(6) DESCRIPTION FSCM	(7) USABLE ON CODE U\M	(8) QTY INC IN UNIT
8	1	XDFZZ		SCB136435	80063 BATTERY BLOCK	EA	1
8	2	XDFZZ		MS35649-64	96906 NUT, PLAIN, HEXAGON	EA	2
8	3	XDFZZ		MS35337-98	96906 WASHER, SPLIT	EA	2
8	4	XDFZZ		SCB136300	80063 CONTACT, ELECTRICAL	EA	2
8	5	XDFZZ	5305-00-889-3001	MS35225-31	96906 SCREW, MACHINE	EA	4
8	6	XDFZZ	5310-00-198-3724	MS35337-41	96906 WASHER, LOCK	EA	4
8	7	XDFZZ	5310-00-013-4530	MS35649-62	96906 NUT, PLAIN, HEXAGON	EA	4
8	8	XDFZZ		SCB136301	80063 SPRING, HLCL, CMPSN	EA	1
8	9	XDFZZ		41-27J	71688 PROTECTOR, TELEPHONE	EA	64
8	10	XDFZZ		MS35333-93	96906 WASHER, LOCK	EA	60
8	11	XDFZZ		SCB136553	80063 NUT, PLAIN, HEXAGON	EA	60
8	12	XDFZZ		SCB136303	80063 WASHER, NONMETALLIC	EA	64
8	13	XDFZZ	5305-00-984-6196	MS35206-248	96906 SCREW, MACHINE	EA	2
8	14	XDFZZ		SCB136434	80063 CLAMP	EA	1
8	15	PAFZZ	5930-00-050-2680	MS35058-9	96906 SWITCH, TOGGLE	EA	2
8	16	XDFZZ		MS35649-104	96906 NUT, PLAIN, HEXAGON	EA	125
8	17	XDFZZ		SCB136284-1	80063 INSULATOR BUSHING	EA	64
8	18	XDFZZ		SCDLI36437GRP3	80063 POST, BINDING	EA	65
8	19	XDFZZ	5360-00-159-0176	SCB136302	80063 SPRING, HELICAL, TORS	EA	1
8	20	XDFZZ		SCB136298	80063 INSULATOR, PLATE	EA	1
8	21	XDFZZ		SCB136299	80063 INSULATOR BUSHING	EA	2
8	22	XDFZZ		SCB136431	80063 STRAP, MOUNTING	EA	1
8	23	XDFZZ		SCB136433	80063 STRAP, MOUNTING	EA	60
8	24	XDFZZ		SCB136432	80063 STRAP, MOUNTING	EA	9
8	25	PAFZZ	5920-00-892-9311	HKPZEQ	71400 FUSEHOLDER, EXTRACTO	EA	1
8	26	PAFZZ	5999-00-244-5150	9435-1-2	71400 CAP, ELECTRICAL	EA	1
8	27	XDFZZ		SCD136430	80063 STRAP, MOUNTING	EA	1
8	28	XDFZZ		SCD136439	80063 PANEL SUBASSEMBLY	EA	1

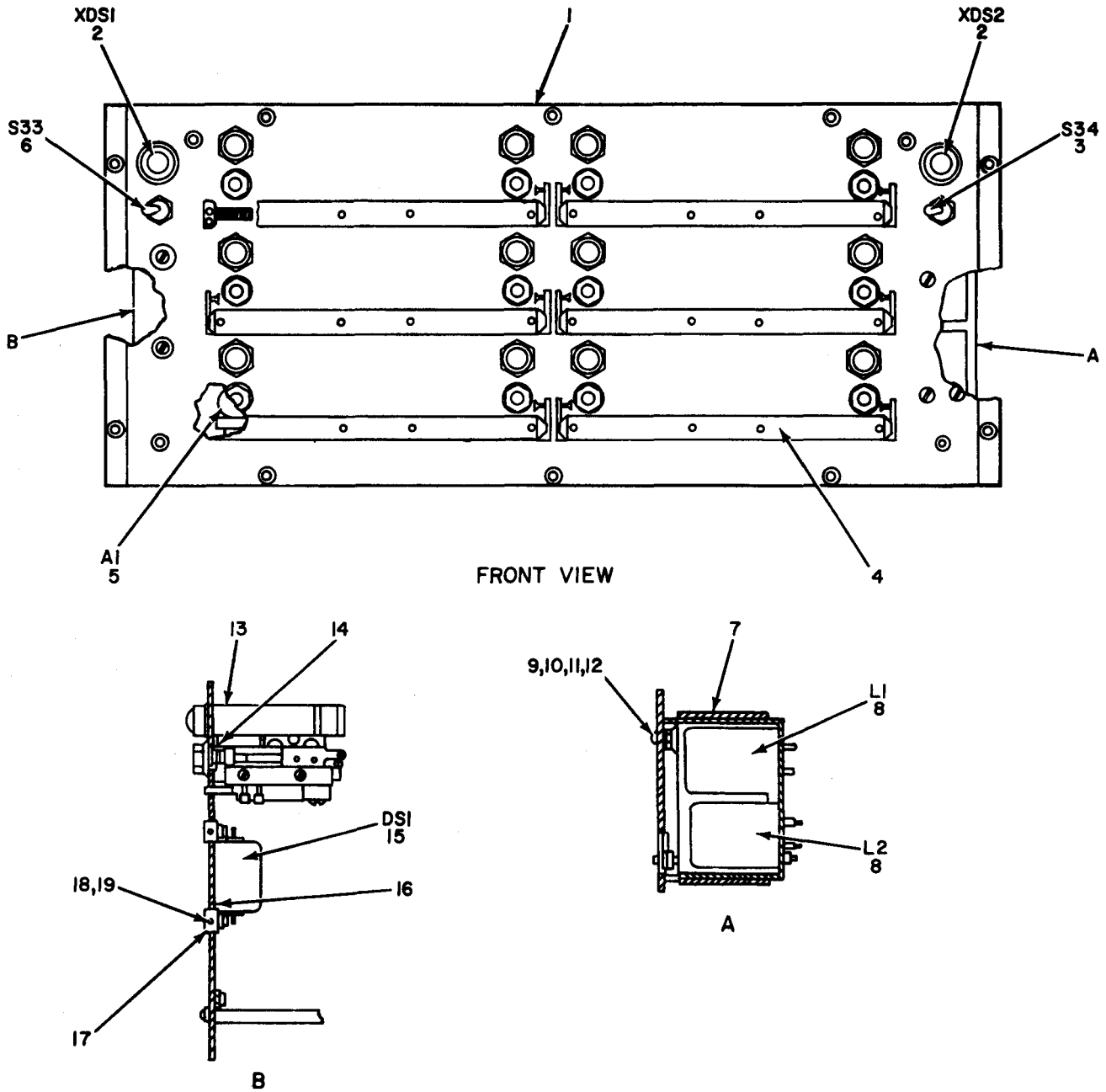

NOTE: PREFIX ALL REFERENCE DESIGNATIONS WITH A3A2A2

ELOISOIO

Figure 9. Chassis Assembly (A3A2), and Panel Assemblies.

(1) ILLUSTRATION (a) FIG NO.	(2) (b) ITEM NO.	(3) SMR CODE	(4) NATIONAL STOCK NUMBER	(5) PART NUMBER	(6) FSCM	(7) DESCRIPTION	(8) USABLE ON CODE	(9) QTY INC IN UNIT
9	1	XDFZZ		SCD136548	80063	PANEL SUBASSEMBLY		EA 1
9	2	XDFZZ		1681	72765	LIGHT, INDICATOR		EA 2
9	3	PAFZZ	5930-00-655-1513	ST42E	04009	SWITCH, TOGGLE		EA 1
9	4	PAFZZ	9905-00-396-3405	SCC136448	80063	PLATE, IDENTIFICATION		EA 6
9	5	XDFFF		SCD136455	80063	JACK ASSY, SWITCH		EA 30
9	6	PAFZZ	5930-00-050-2680	MS35058-9	96906	SWITCH, TOGGLE		EA 1
9	7	XDFZZ		SCB136557	80063	BRACKET, MOUNTING		EA 1
9	8	PAFZZ	5950-00-645-4432	SCB136306	80063	COIL, TELEPHONE		EA 2
9	9	XDFZZ		MS35241-50	96906	SCREW, MACHINE		EA 4
9	10	PAFZZ	5310-00-809-8544	MS27183-7	96906	WASHER, FLAT		EA 4
9	11	PAFZZ	5310-00-045-3299	MS35337-42	96906	WASHER, SPLIT		EA 4
9	12	PAFZZ	5310-00-012-0622	MS35649-82	96906	NUT, PLAIN, HEXAGON		EA 4
9	13	XDFZZ		SCC136508GRP2	80063	SIGNAL, SWITCH BOARD		EA 30
9	14	XDFZZ	9905-00-396-3405	SCC136447	80063	PLATE, IDENTIFICATION		EA 6
9	15	PAFZZ	6350-00-351-8022	SCB136550	80063	BUZZER		EA 1
9	16	XDFZZ		SCB136445	80063	INSULATOR, PLATE		EA 1
9	17	XDFZZ		SCB136446	80063	INSULATOR, BUSHING		EA 2
9	18	XDFZZ	5305-00-889-3000	MS35225-30	96906	SCREW, MACHINE		EA 2
9	19	XDFZZ		68NM62	72962	NUT, SLPLKG, HEXAGON		EA 2

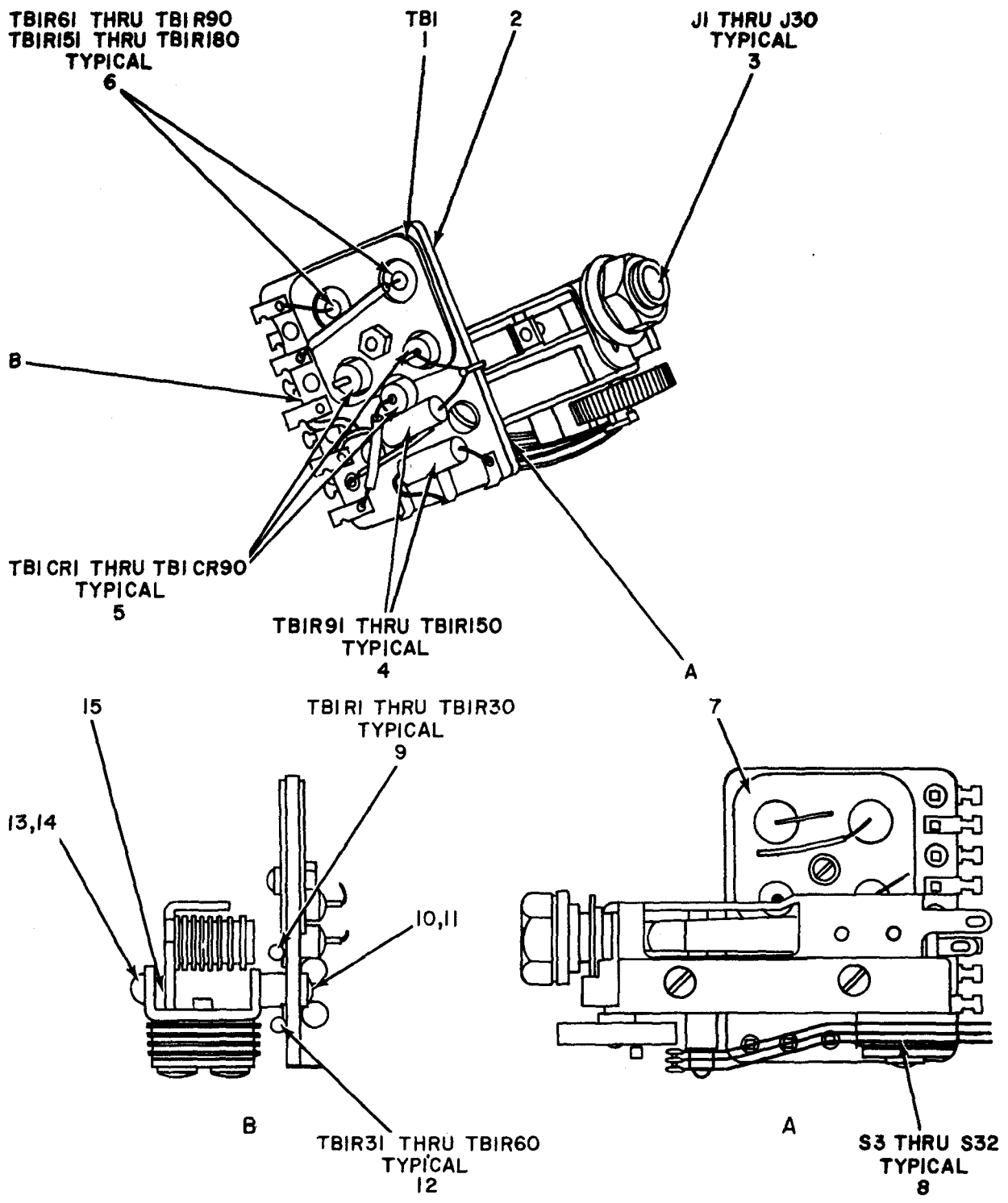

NOTE: PREFIX ALL REFERENCE DESIGNATIONS WITH A3A2A2A1

ELOIS011

Figure 10. Jack Assembly Switch (A3A2A2A1).

(1)	(2)	(3)	(4)	(5)	(6)	(7)	(8)
ILLUSTRATION							QTY
(a)	(b)	NATIONAL			DESCRIPTION		INC
FIG	ITEM	SMR	STOCK	PART			IN
NO.	NO.	CODE	NUMBER	NUMBER	FSCM	USABLE ON CODE	U\M
							UNIT
GROUP 030101 JACK ASSEMBLY SWITCH (A3A2A2A1)							
10	1	PAFZZ	5805-00-926-3226	SCC136483	80063	ELECTRONIC COMPONENT	EA 30
10	2	XDFZZ	5940-00-643-5321	SCB136485	80063	TERMINAL BOARD	EA 30
10	3	PAFZZ	5935-00-201-8997	SCC136457	80063	JACK, TELEPHONE	EA 30
10	4	PAFZZ	5905-00-279-2019	RC20GF512J	81349	RESISTOR, FIXED, COMP	EA 60
10	5	XDFZZ		SCB136556	80063	RECTIFIER, METALLIC	EA 90
10	6	PAFZZ	5920-00-285-0887	SCB136555	80063	ARRESTER, ELECTRICAL	EA 60
10	7	XDFZZ		SCB136484	80063	INSULATOR, PLATE	EA 60
10	8	PAFZZ	5930-00-548-5988	SCC136487	80063	SWITCH, ROTARY	EA 30
10	9	PAFZZ	5905-00-279-3511	RC20GF511J	81349	RESISTOR, FXD, CMPSN	EA 30
10	10	PAFZZ	5305-00-993-0190	MS35206-214	96906	SCREW, MACHINE	EA 60
10	11	PAFZZ	5310-00-934-9748	MS35649-244	96906	NUT, PLAIN, HEXAGON	EA 60
10	12	PAFZZ	5905-00-110-0196	RCR20G102JS	81349	RESISTOR, FXD, CMPSN	EA 30
10	13	XDFZZ	5305-00-889-2997	MS35206-215	96906	SCREW, MACHINE	EA 60
10	14	PAFZZ	5310-00-638-6873	MS35333-97	96906	WASHER, LOCK	EA 60
10	15	XDFZZ		SCB136456	80063	INSULATOR, PLATE	EA 30

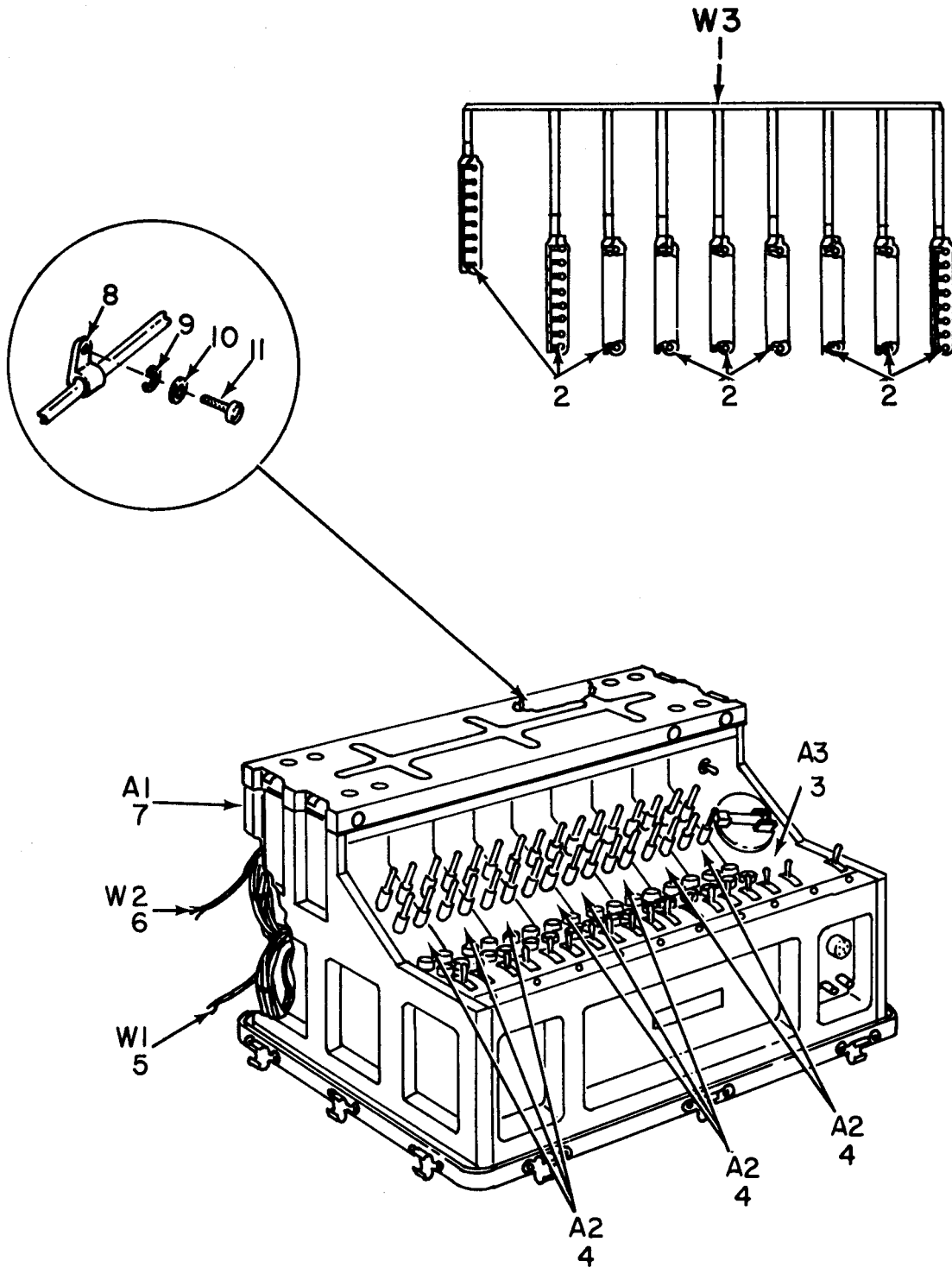

NOTE: PREFIX ALL REFERENCE DESIGNATIONS WITH A4.

ELOIS012

Figure 11. Telephone Switch Section (A4).

(1)	(2)	(3)	(4)	(5)	(6)	(7)	(8)
ILLUSTRATION							QTY
(a)	(b)	NATIONAL			DESCRIPTION		INC
FIG	ITEM	SMR	STOCK	PART			IN
NO.	NO.	CODE	NUMBER	NUMBER	FSCM	USABLE ON CODE	U\M
							UNIT
GROUP 04 TELEPHONE SWITCH SECTION (A4)							
11	1	XDFZZ		SCD136626	80063		EA 1
11	2	XDFZZ	5940-00-392-7936	SCB136628	80063		EA 9
11	3	PAOFF	5805-00-356-2738	TA220P	80058		EA 1
11	4	PAOFF	5805-00-503-3343	TA208P	80058		EA 8
11	5	XDFZZ		SCB136602	80063		EA 1
11	6	PAFZZ	5995-00-537-5493	SCB136603	80063		EA 1
11	7	XDFZZ		SCD136604	80063		EA 1
11	8	XDFZZ		3-5-16	95987		EA 4
11	9	PAFZZ	5310-00-045-3299	MS535337-42	96906		EA 4
11	10	PAFZZ	5310-00-680-6745	MS15795	96906		EA 4
11	11	XDFZZ	5305-00-889-3002	MS35206-242	96906		EA 4

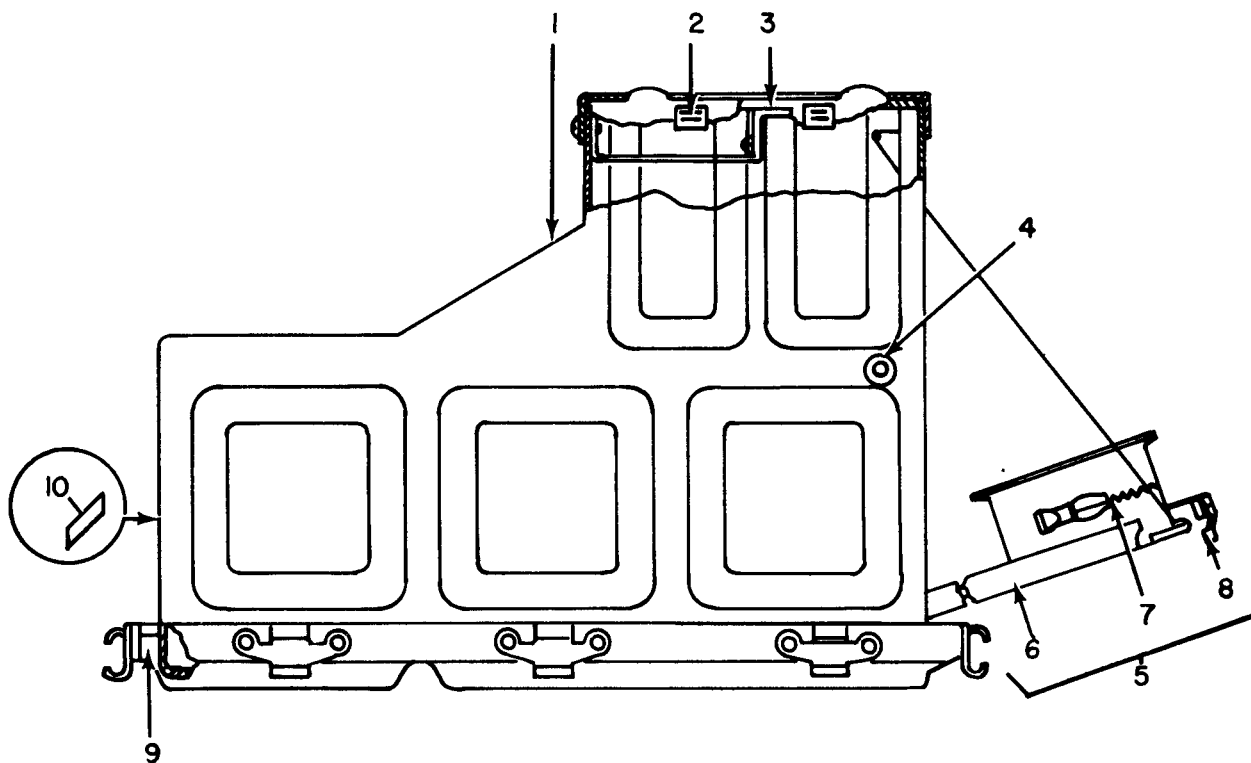

ELOIS013

Figure 12. Telephone Switch Section (A4), and Cabinet Assembly.

(1)	(2)	(3)	(4)	(5)	(6)	(7)	(8)	
ILLUSTRATION							QTY	
(a)	(b)	NATIONAL			DESCRIPTION		INC	
FIG	ITEM	SMR	STOCK	PART			IN	
NO.	NO.	CODE	NUMBER	NUMBER	FSCM	USABLE ON CODE	U/M	
							UNIT	
12	1	XDFFF		SCD136618	80063	CABINET ASSEMBLY	EA	1
12	2	PAFZZ	5340-00-396-3441	SCB136411	80063	STRIKE,CATCH	EA	4
12	3	XDFZZ		SCC136609	80063	PLATE ASSEMBLY	EA	1
12	4	PAFZZ	5325-00-281-1557	AN931-10-14	88044	GROMMET,NONMETALLIC	EA	2
12	5	XDFFF		SCC136611	80063	DOOR ASSEMBLY	EA	1
12	6	XDFZZ		SCC136616	80063	DOOR	EA	1
12	7	XDFZZ		SCC136611-1	80063	BAG,COTTON DUCK	EA	1
12	8	PAFZZ	5325-00-285-2017	2600-1	71286	STUD ASSEMBLY,TURN	EA	3
12	9	PAFZZ	5330-00-392-5793	SCB136605	80063	GASKET	EA	1
12	10	XDFFF		SCB136606	80063	PLATE,IDENT	EA	1

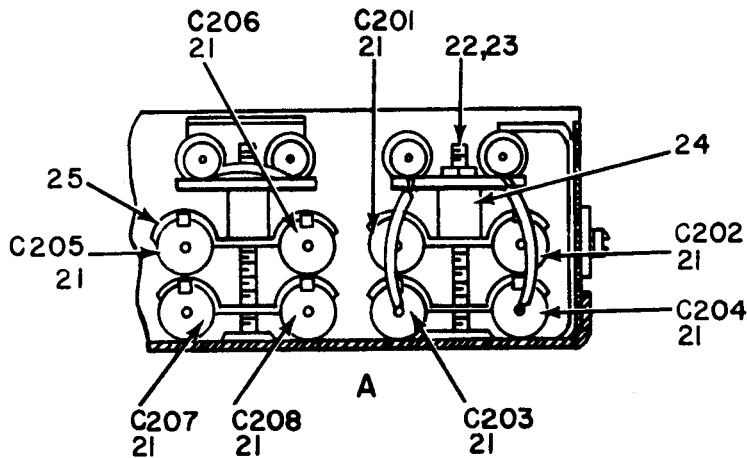
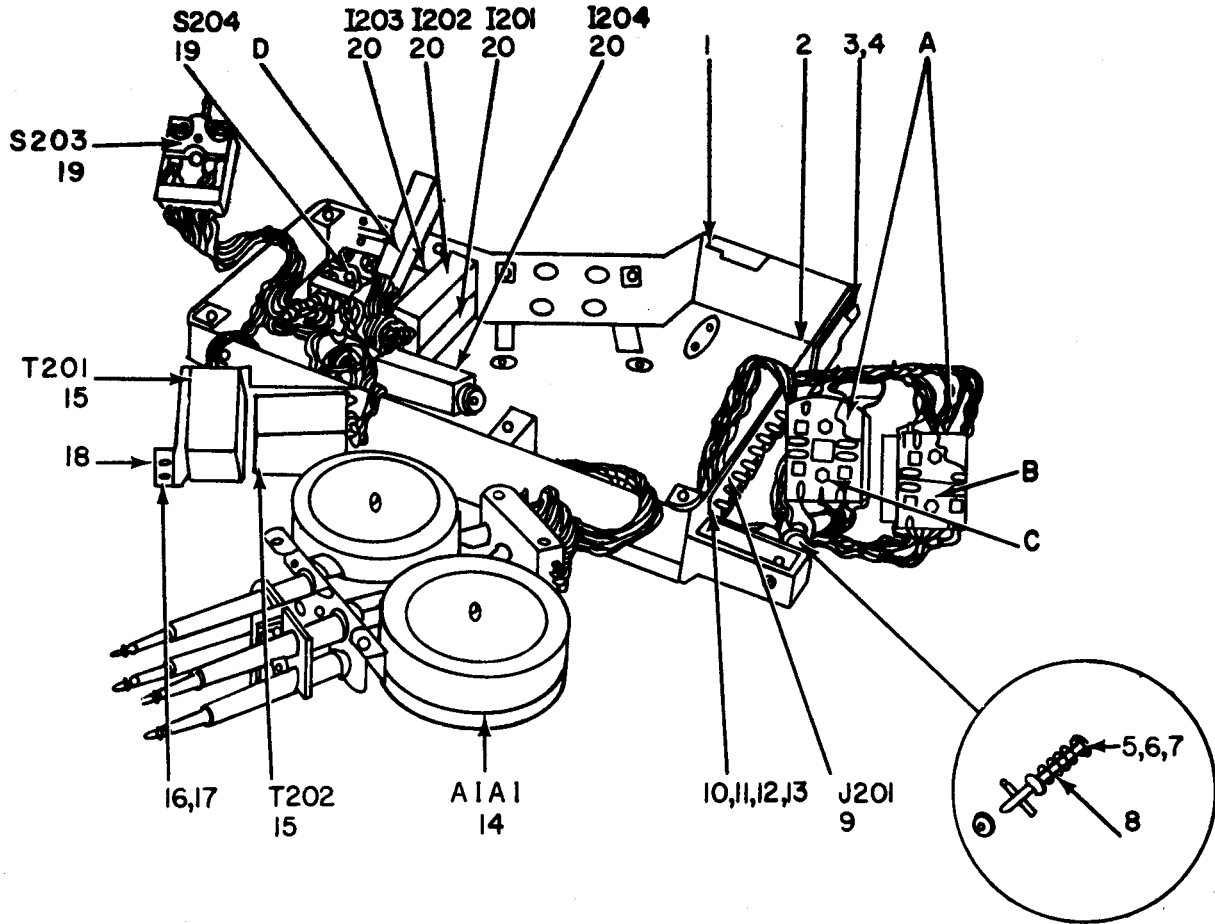

NOTE: PREFIX ALL REFERENCE DESIGNATIONS WITH A4A3.

ELOISO14

Figure 13. Telephone Circuit Card (A4A3) (Sheet 1 of 3).

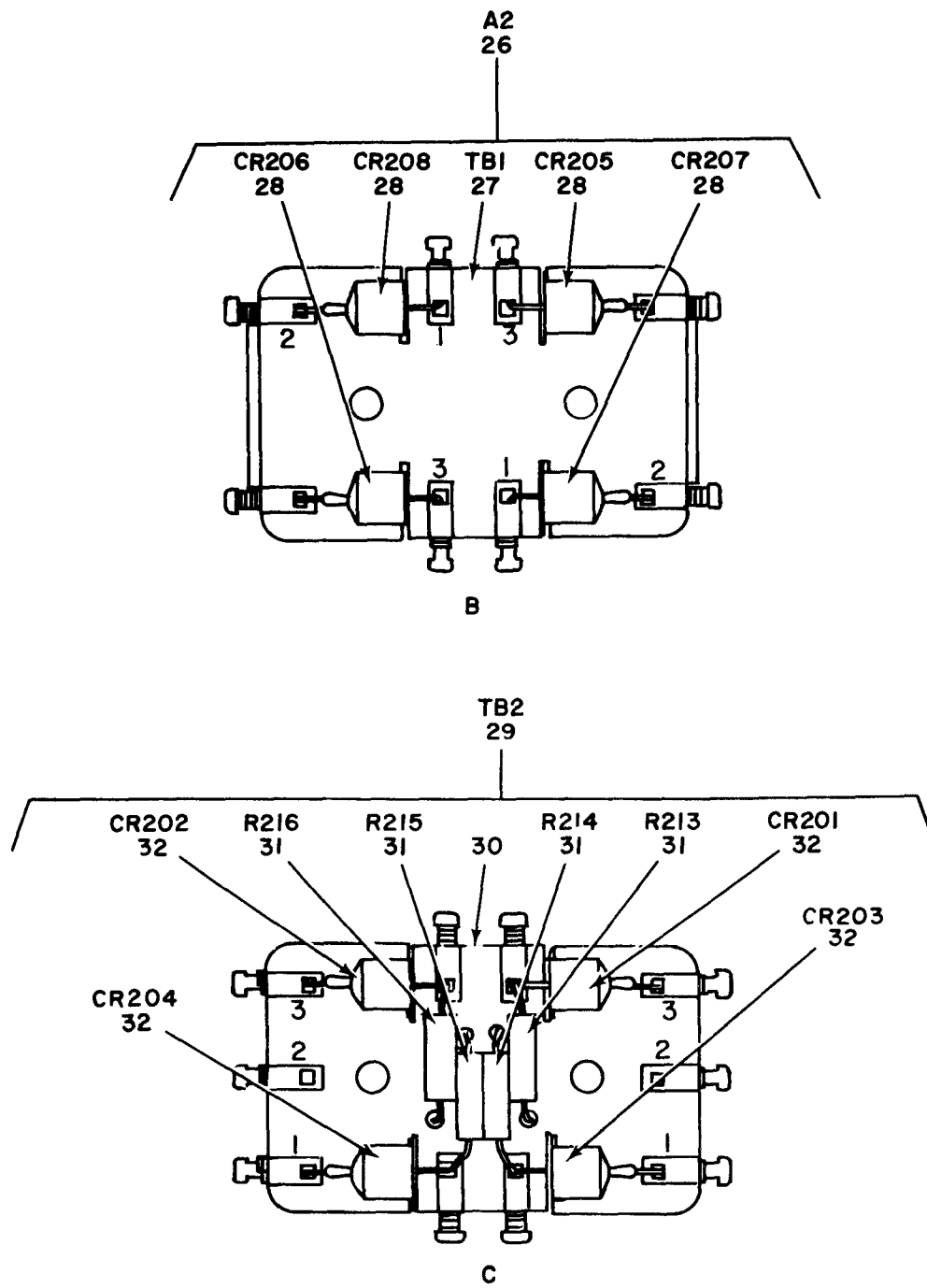

NOTE: PREFIX ALL REFERENCE DESIGNATIONS WITH A4A3.

ELOIS015

Figure 13. Telephone Circuit Card (A4A3) (Sheet 2 of 3).

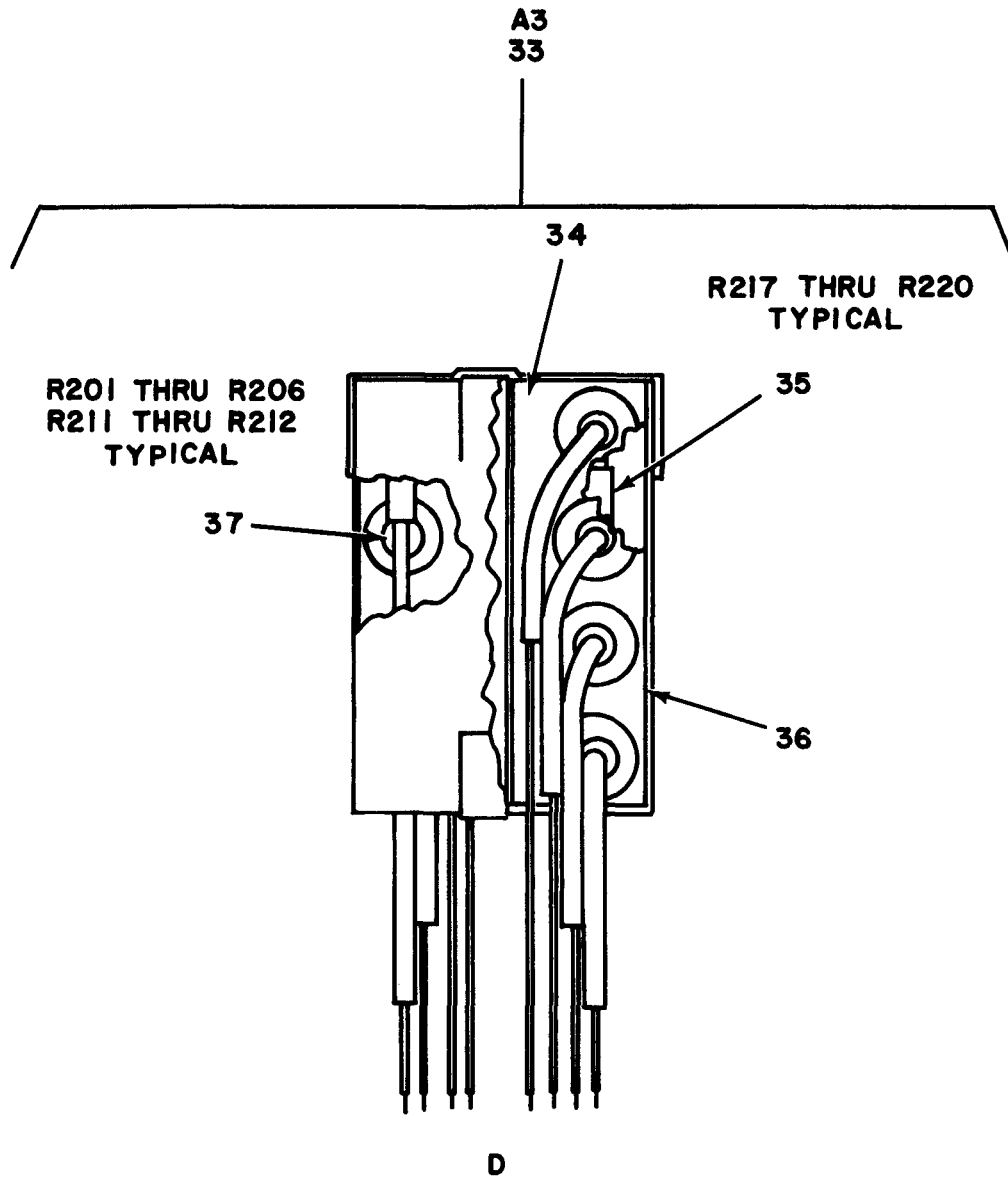

NOTE: PREFIX ALL REFERENCE DESIGNATIONS WITH A4A3.

ELOIS016

Figure 13. Telephone Circuit Card (A4A3) (Sheet 3 of 3).

SECTION II

TM11-5805-304-24P

(1) ILLUSTRATION (a) FIG NO.	(2) ITEM NO.	(3) SMR CODE	(4) NATIONAL STOCK NUMBER	(5) PART NUMBER	(6) DESCRIPTION FSCM	(7) USABLE ON CODE U\M	(8) QTY INC IN UNIT
GROUP 0401 TELEPHONE CIRCUIT CARD (A4A3)							
13	1	XDFFF		SCD136207	80063 CASE TELEPHONE CKT	EA	1
13	2	XDFZZ		SCB136331	80063 COVER	EA	1
13	3	PAFZZ	5305-00-883-8377	SCB136223	80063 SCREW, EXTERNALLY RE	EA	1
13	4	PAFZZ	5310-00-045-3299	MS35337-42	96906 WASHER, SPLIT	EA	1
13	5	XDFZZ		5133-31	79136 RING, RETAINING	EA	1
13	6	PAFZZ	5305-00-882-4055	SCB136222	80063 SCREW, SHOULDER	EA	1
13	7	XDFZZ		SCD136201-7	80063 WASHER, FLAT	EA	1
13	8	XDFZZ		SCB136202	80063 SPRING, HLCPS	EA	1
13	9	XDFZZ	5935-00-393-1947	SCB136219	80063 TERMINAL BOARD	EA	1
13	10	PAFZZ	5305-00-984-6193	MS35206-245	96906 SCREW, MACHINE	EA	8
13	11	PAFZZ	5310-00-809-8544	MS27183-7	96906 WASHER, FLAT	EA	2
13	12	PAFZZ	5310-00-045-3299	MS35337-42	96906 WASHER, SPLIT	EA	2
13	13	PAFZZ	5310-00-012-0622	MS35649-82	96906 NUT, PLAIN, HEXAGON	EA	2
13	14	XDFFF		SCD136232	80063 REEL ASSEMBLY	EA	2
13	15	XDFZZ		SCD136313	80063 COIL, TELEPHONE	EA	2
13	16	PAFZZ	5305-00-043-5885	MS35225-27	96906 SCRW, MACHINE	EA	4
13	17	XDFZZ		68NM62	72962 NUT, SLFLKG, HEXAGON	EA	4
13	18	XDFZZ		SCB136342	80063 BRACKET, MOUNTING	EA	1
13	19	PAFZZ	5930-00-549-7493	SCD136320	80063 SWITCH, LEVER	EA	2
13	20	XDFZZ		SCC136508GRP1	80063 SIGNAL, SWITCH-BOARD	EA	4
13	21	PAFZZ	5910-00-681-9093	P123ZN	00656 CAPACITOR, FXD, PAPER	EA	8
13	22	PAFZZ	5305-00-043-6672	MS35225-37	96906 SCREW, MACHINE	EA	4
13	23	XDFZZ		68NM62	72962 NUT, SLFLKG, HEXAGON	EA	4
13	24	XDFZZ		SCB136227-1	80063 INSULATOR, BUSHING	EA	4
13	25	XDFZZ		SCB136206	80063 CLAMP, ELECTRICAL	EA	4
13	26	XDFFF		SCB136328	80063 TERMINAL BOARD	EA	1
13	27	XDFZZ		SCB136329	80063 TERMINAL BOARD	EA	1
13	28	PAFZZ	5805-00-926-3226	SCC136483	80063 ELECTRONIC COMPONENT	EA	4
13	29	XDFFF		SCB136325	80063 TERMINAL BOARD	EA	1
13	30	XDFZZ		SCB136326	80063 TERMINAL BOARD	EA	1
13	31	PAFZZ	5905-00-190-8887	RC20GF202J	81349 RESISTOR, FIXED, COMP	EA	4
13	32	XDFZZ		SCB136228	80063 RECTIFIER, METALLIC	EA	4
13	33	XDFFF		SCB136230	80063 RESISTOR ASSEMBLY	EA	1
13	34	XDFZZ		SCB136230	80063 BRACKET, MOUNTING	EA	2
13	35	PAFZZ	5905-00-279-2522	RC20GF154J	81349 RESISTOR, FIXED, COMP	EA	4
13	36	XDFZZ		SCB136229	80063 TUBE, MOUNTING	EA	1
13	37	PAFZZ	5920-00-285-0887	SCB136555	80063 ARRESTER, ELECTRICAL	EA	8

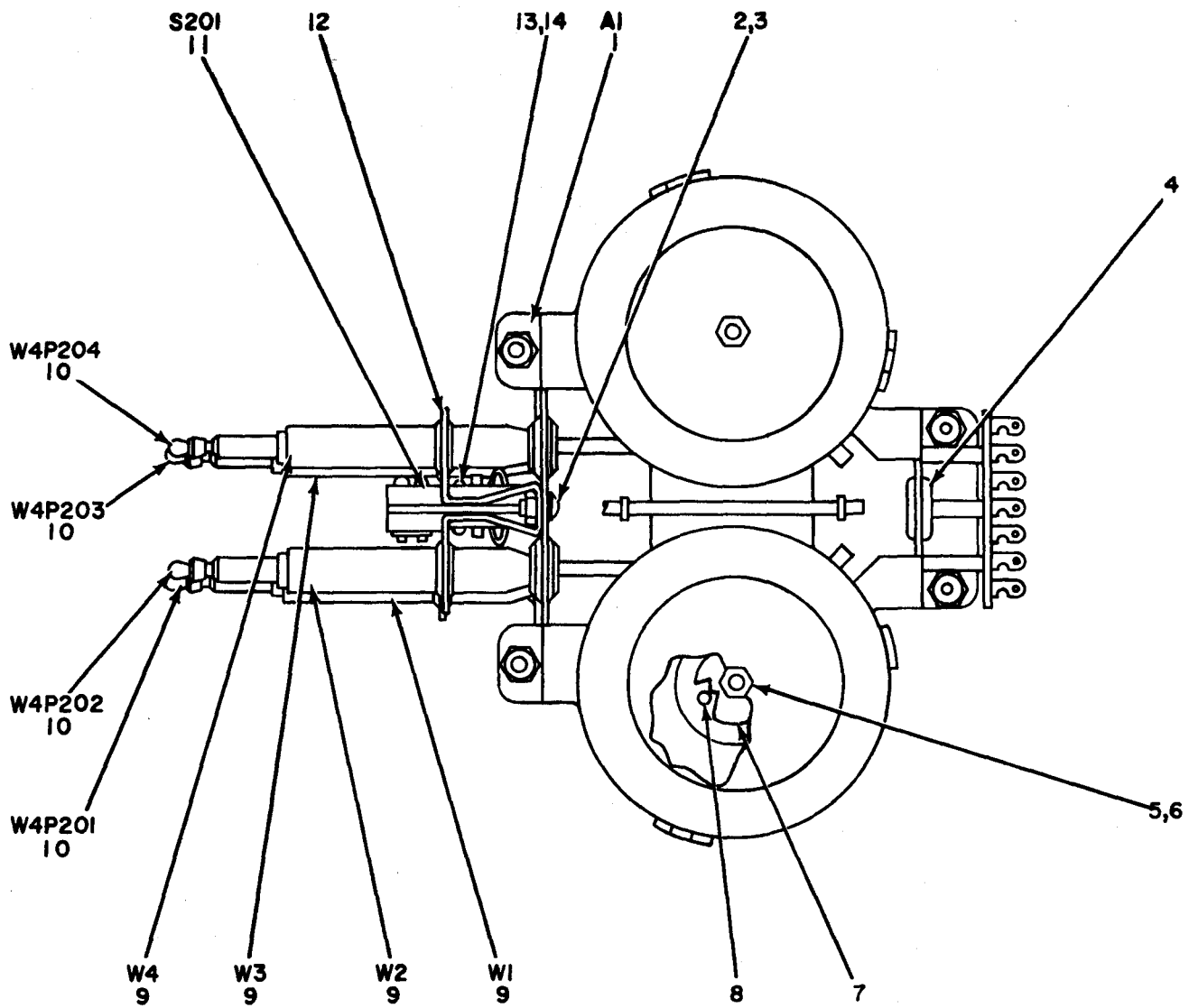

**NOTE: PREFIX ALL REFERENCE DESIGNATIONS
WITH A4A3A1A1**

ELOIS017

Figure 14. Reel Assembly (A4A3A1A1).

(1) ILLUSTRATION (a) FIG NO.	(2) (b) ITEM NO.	(3) SMR CODE	(3) NATIONAL STOCK NUMBER	(4) PART NUMBER	(5) FSCM	(6) DESCRIPTION	(7) USABLE ON CODE	(8) QTY INC IN U\M UNIT
GROUP 040101 REEL ASSEMBLY (A4A3A1A1)								
14	1	XDFFF		SCC136239	80063	BRACKET, MOUNTING	EA	1
14	2	XDFZZ	5305-00-988-1167	MS35225-4	96906	SCREW, MACHINE	EA	2
14	3	XDFZZ	5310-00-840-6791	68NM50	72962	NUT, SLEF-LOCKING, HE	EA	4
14	4	PAPZZ	5325-00-281-1557	AN931-10-14	88044	GROMMET, NONMETALLIC	EA	1
14	5	XDFZZ		SCB136237	80063	BOLT, MACHINE	EA	2
14	6	XDFZZ	5310-00-820-0931	SCB136235	80063	WASHER, FLAT	EA	4
14	7	XDFZZ		SCB136234	80063	WASHER, NON-METALLIC	EA	8
14	8	XDFZZ		SCB136236	80063	PIN, STR, HEADLESS	EA	6
14	9	XDFFF		SCC48305, GRP1	80063	CORD ASSY, ELEC	EA	4
14	10	PAPZZ	5935-00-837-5969	PJ-051R	81349	PLUG, TELEPHONE	EA	4
14	11	PAPZZ	5930-00-324-9119	SCC136246	80063	SWITCH SUBASSEMBLY	EA	1
14	12	XDFZZ		SCB136242	80063	BRACKET, MOUNTING	EA	2
14	13	XDFZZ	5310-00-685-3443	68NM26	72962	NUT, SELF-LOCKING, HE	EA	2
14	14	XDFZZ		100-7S5-6	80063	SCREW, MACHINE	EA	2

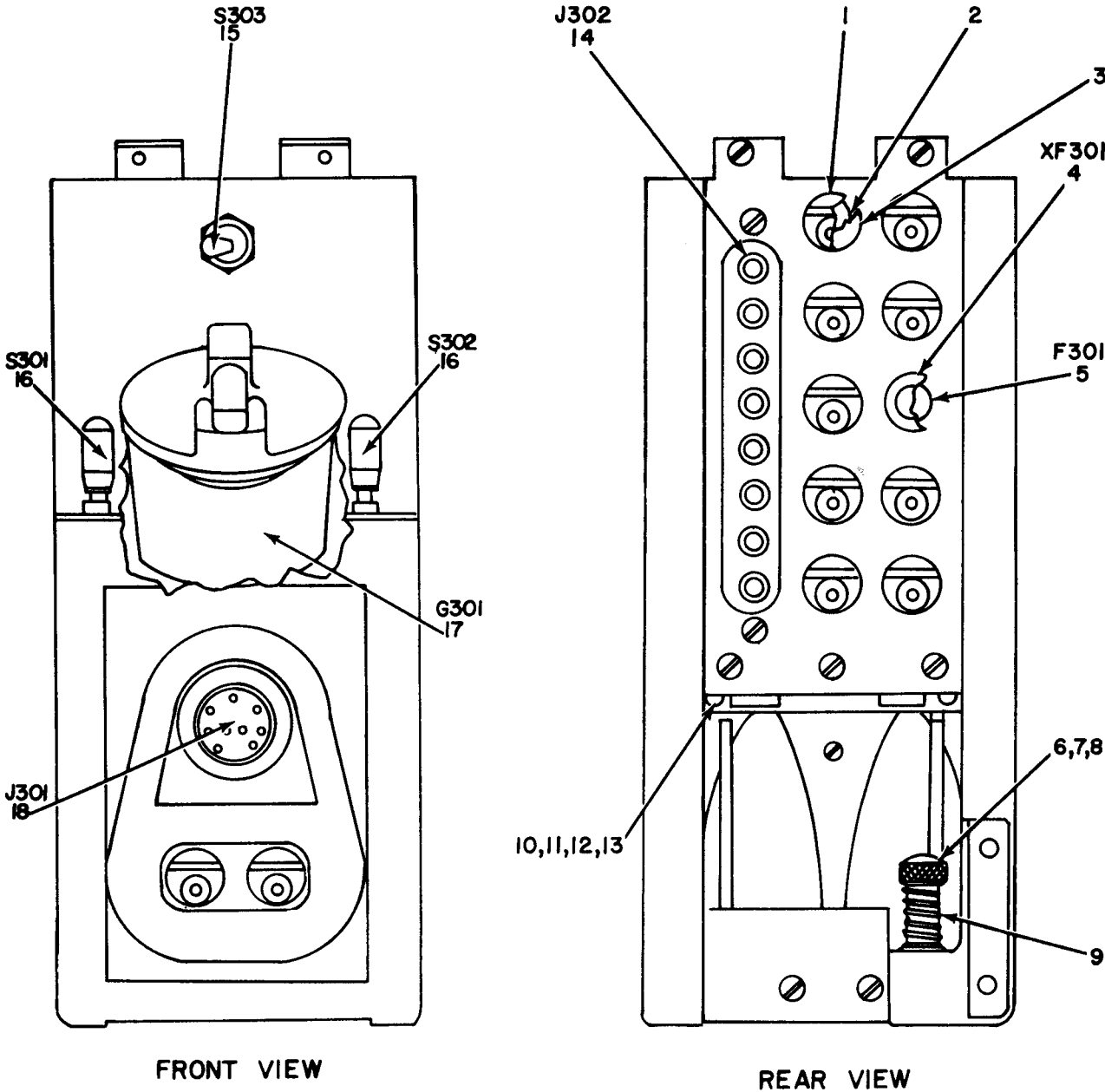

NOTE: PREFIX ALL REFERENCE DESIGNATIONS WITH A4A4.

ELJIS018

Figure 15. Operator's Telephone Circuit (A4A4), (Sheet 1 of 2).

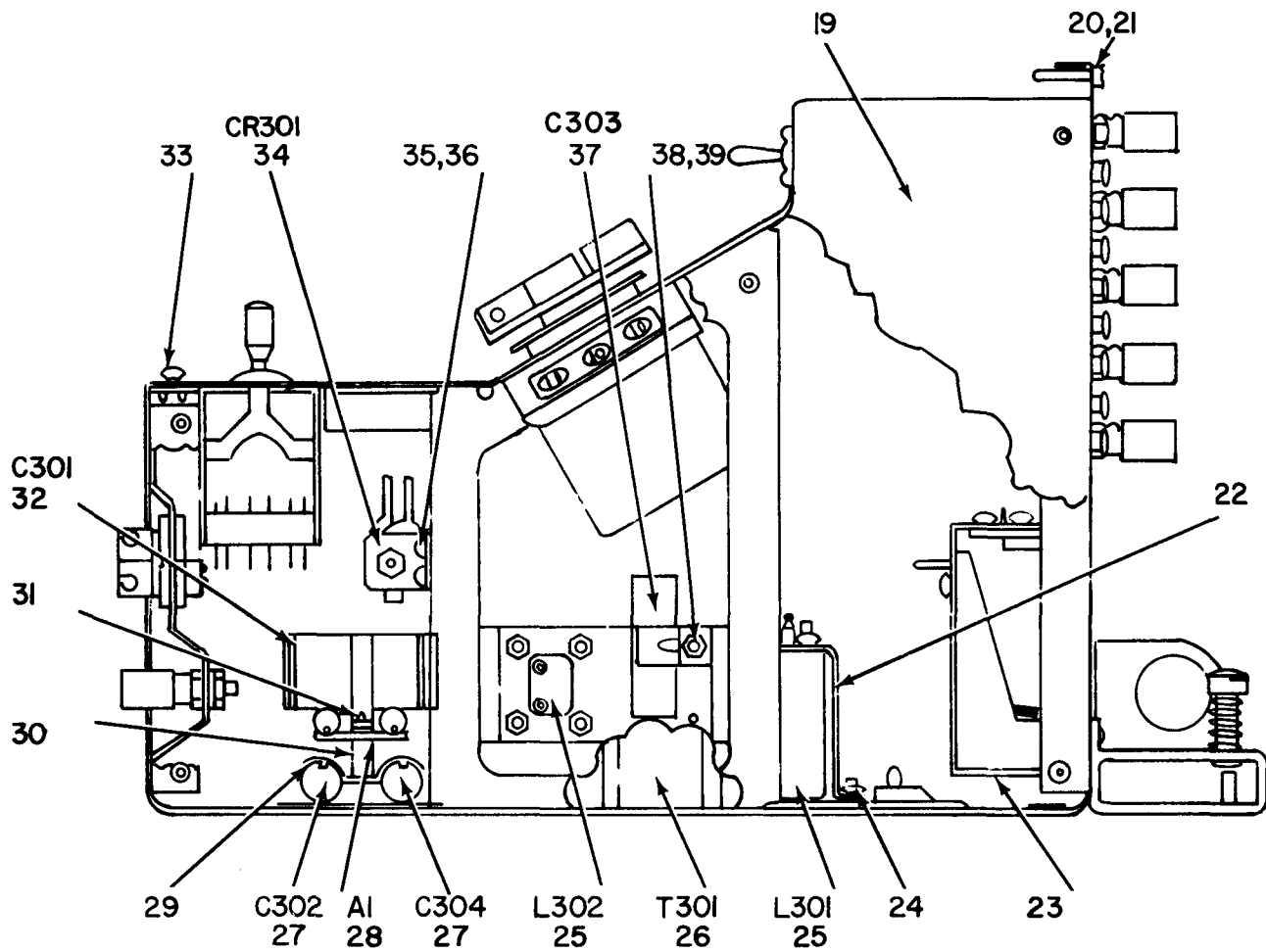

NOTE: PREFIX ALL REFERENCE DESIGNATIONS WITH A4A4

ELOIS019

Figure 15. Operator's Telephone Circuit (A4A4), (Sheet 2 of 2).

SECTION II

TM11-5805-304-24P

(1) ILLUSTRATION (a) FIG NO.	(2) ITEM NO.	(3) SMR CODE	(4) NATIONAL STOCK NUMBER	(5) PART NUMBER	(6) FSCM	DESCRIPTION	(7) USABLE ON CODE	(8) QTY INC IN UNIT
GROUP 0402 OPERATOR'S TELEPHONE CIRCUIT (A4A4)								
15	1	XDFZZ		SCDL136437GRP3	80063	POST,BINDING	EA	11
15	2	XDFZZ		SCB136284-1	80063	INSULATOR BUSHING	EA	9
15	3	XDFZZ		SCB136303	80063	WASHER, NON METALLIC	EA	9
15	4	9AFZZ	5920-00-892-9311	HKPZEQ	71400	FUSEHOLDER	EA	1
15	5	PAFZZ	5920-00-284-9454	3131-25	60016	FUSE, CARTRIDGE	EA	1
15	6	PAFZZ	5305-00-882-4055	SCB136222	80063	SCREW, SHOULDER	EA	1
15	7	XDFZZ		5133-31	79136	RING, RETIANING	EA	1
15	8	XDFZZ		SCD136201-7	80063	WASHER, FLAT	EA	1
15	9	XDFZZ		SCB136202	80063	SPRING, HLCPS	EA	1
15	10	PAFZZ	5305-00-984-6193	MS35206-245	96906	SCREW, MACHINE	EA	2
15	11	PAFZZ	5310-00-809-8544	MS27183-7	96906	WASHER, FLAT	EA	2
15	12	PAFZZ	5310-00-045-3299	MS35337-42	96906	WASHER, SPLIT	EA	4
15	13	PAFZZ	5310-00-012-0622	MS35649-82	96906	NUT, PLAIN, HEXAGON	EA	2
15	14	XDFZZ	5935-00-393-1947	SCB136219	80063	TERMINAL BOARD	EA	1
15	15	PAFZZ	5930-00-050-2680	MS35058-9	96906	SWITCH, TOGGLE	EA	1
15	16	PAFZZ	5930-00-259-7528	SCC84553	80063	SWITCH, LEVER	EA	2
15	17	XDFZZ		SCD18034	80063	GENERATOR, HND RNGG	EA	1
15	18	PAFZZ	5935-00-549-2646	SCD83050	80063	CONNECTOR, RECEPTACL	EA	1
15	19	XDFZZ		SCB136331	80063	COVER	EA	1
15	20	PAFZZ	5305-00-883-8377	SCB136223	80063	SCREW, EXTERNALLY RE	EA	2
15	21	PAFZZ	5310-00-045-3299	MS35337-42	96906	WASHER, SPLIT	EA	1
15	22	XDFZZ		SCB136204	80063	BRACKET MOUNTING	EA	1
15	23	XDFZZ	6140-00-333-9737	SCC136295	80063	BATTERY BOX	EA	1
15	24	PAFZZ	5305-00-043-5885	MS35225-27	96906	SCREW, MACHINE	EA	11
15	25	PAFZZ	5950-00-645-4432	SCB136306	80063	COIL, TELEPHONE	EA	2
15	26	9FZZ	5950-00-645-4464	SCC84598	80063	TRANSFORMER, AUDIO F	EA	1
15	27	9AFZZ	5910-00-681-9093	P123ZN	00656	CAPACITOR, FXD, PAPER	EA	2
15	28	XDFFF		SCC136335	80063	TERMINAL BOARD	EA	1
15	29	XDFZZ		SCB136206	80063	CLAMP, ELECTRICAL	EA	1
15	30	XDFZZ		SCB136227-3	80063	INSULATOR, BUSHING	EA	2
15	31	XDFZZ		68NM62	72962	NUT, SLFLKG, HEXAGON	EA	1
15	32	XDFZZ		CP27A1EC504K1	81349	CAPACITOR, FXD, PAPER	EA	1
15	33	XDFZZ	5305-00-995-6653	MS35190-222	96906	SCREW, MACHINE	EA	8
15	34	XDFZZ		SCB136305	80063	RESISTOR, V SENS	EA	1
15	35	XDFZZ	5305-00-984-4989	MS35206-229	96906	SCREW, MACHINE	EA	2
15	36	XDFZZ		68NM62	72962	NUT, SLFLKG, HEXAGON	EA	2
15	37	XDFZZ		P123ZMB2MP	00656	CAPACITOR, FXD, PAPER	EA	1
15	38	XDFZZ	5305-00-984-4983	MS35206-226	96906	SCREW, MACHINE	EA	1

(1)	(2)	(3)	(4)	(5)	(6)	(7)	(8)
ILLUSTRATION							QTY
(a)	(b)		NATIONAL		DESCRIPTION		INC
FIG	ITEM	SMR	STOCK	PART			IN
NO.	NO.	CODE	NUMBER	NUMBER	FSCM	USABLE ON CODE	U\M UNIT
15	39	XDFZZ		68NM62	72962	NUT,SLFLKG,HEXAGON	EA 1

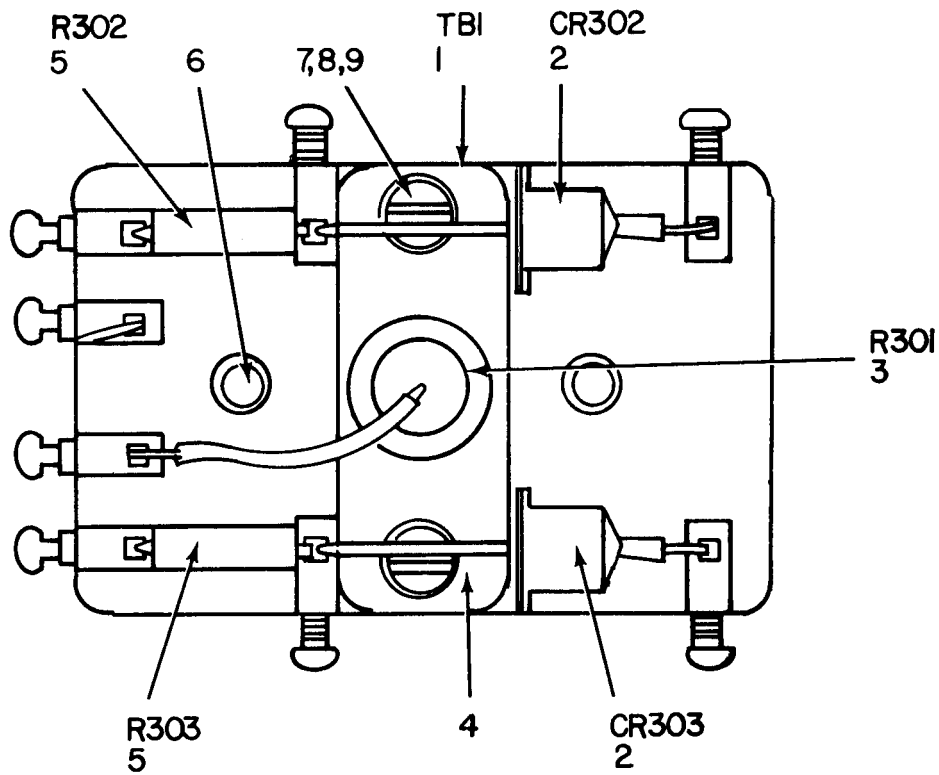

NOTE: PREFIX ALL REFERENCE DESIGNATIONS WITH A4A4A1.

ELOIS020

Figure 16. Terminal Board (A4A4A1).

(1)	(2)	(3)	(4)	(5)	(6)	(7)	(8)	
ILLUSTRATION							QTY	
(a)	(b)	NATIONAL			DESCRIPTION		INC	
FIG	ITEM	SMR	STOCK	PART			IN	
NO.	NO.	CODE	NUMBER	NUMBER	FSCM	USABLE ON CODE	U\M	UNIT
GROUP 040201 TERMINAL BOARD (A4A4A1)								
16	1	XDFZZ		SCB136337	80063	TERMINAL BOARD	EA	1
16	2	XDFZZ		SCB136556	80063	RECTIFIER, METALLIC	EA	2
16	3	PAFZZ	5920-00-285-0887	SCB136555	80063	ARRESTER, ELECTRICAL	EA	1
16	4	XDFZZ		SCB136336	80063	INSULATOR, PLATE	EA	1
16	5	PAFZZ	5905-00-190-8887	RC20GF202J	81349	RESISTOR, FIXED, COMP	EA	2
16	6	PAFZZ	5305-00-984-6222	MS35206-235	96906	SCREW, MACHINE	EA	2
16	7	PAFZZ	5305-00-993-0190	MS35206-214	96906	SCREW, MACHINE	EA	2
16	8	XDFZZ		MS35333-29	96906	WASHER, LOCK	EA	2
16	9	PAFZZ	5310-00-934-9739	MS35649-242	96906	NUT, PLAIN, HEXAGON	EA	2

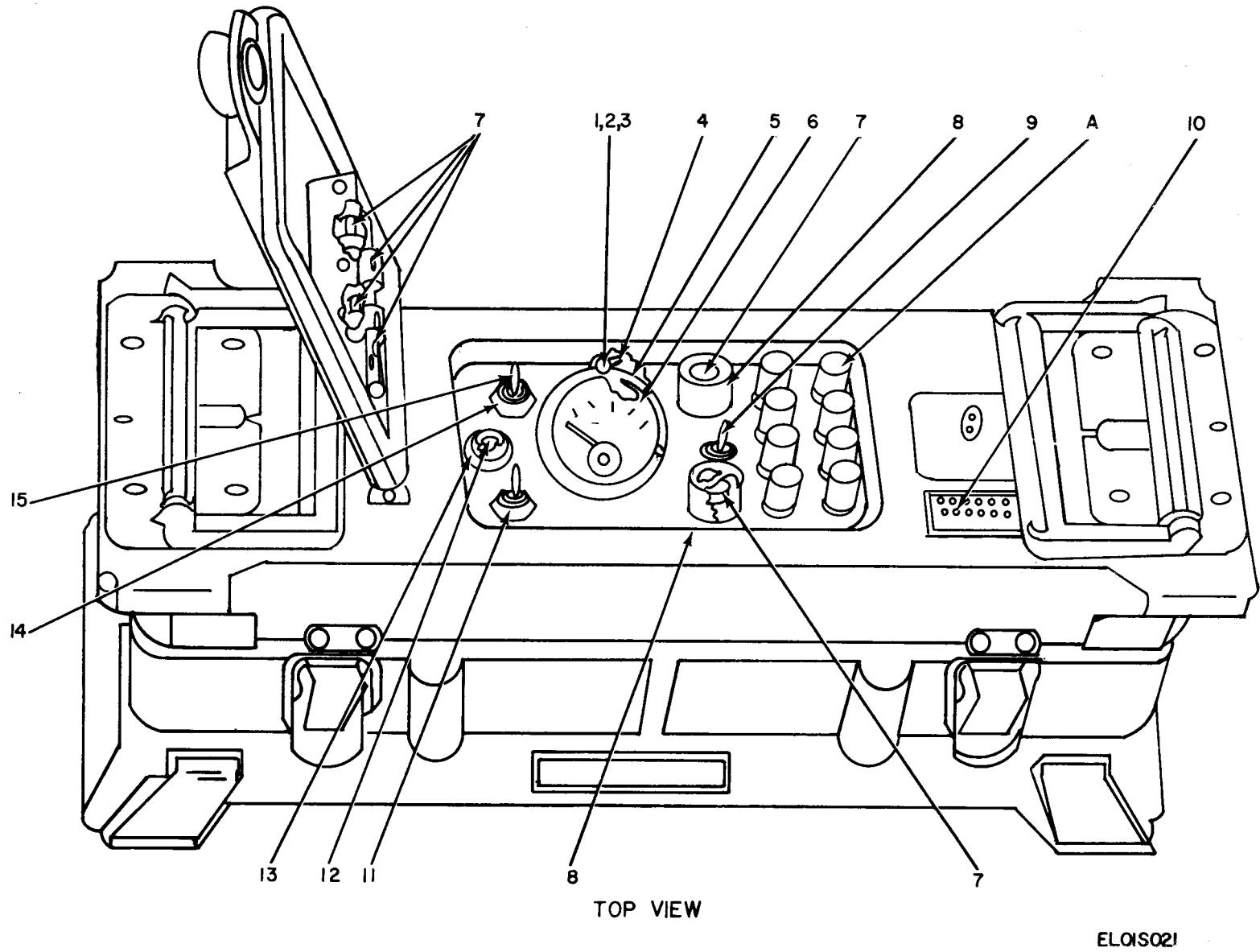
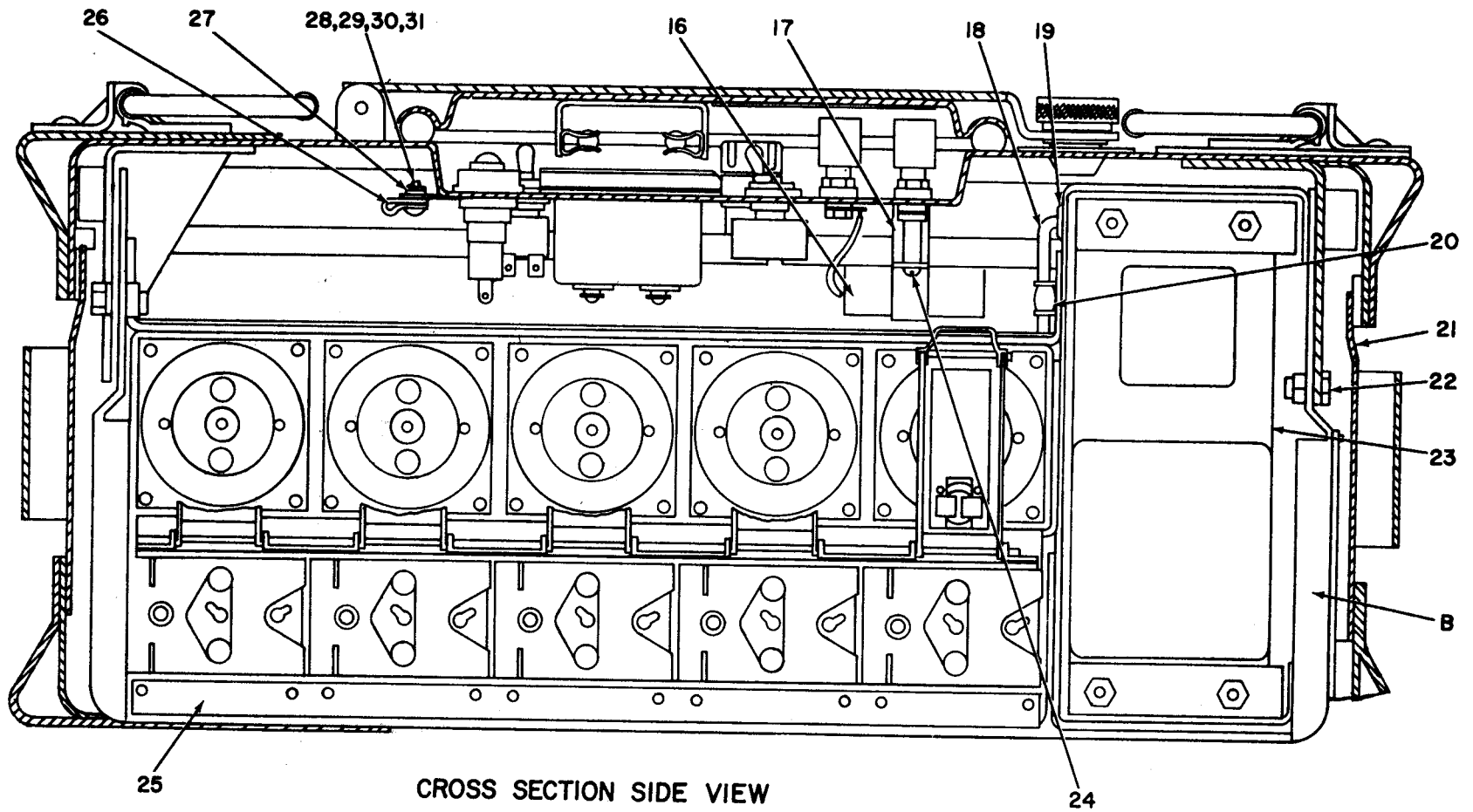

Figure 17. Power Supply PP-990/G, (Sheet 1 of 3).



CROSS SECTION SIDE VIEW

ELOISO22

Figure 17. Power Supply PP-990/G, (Sheet 2 of 3).

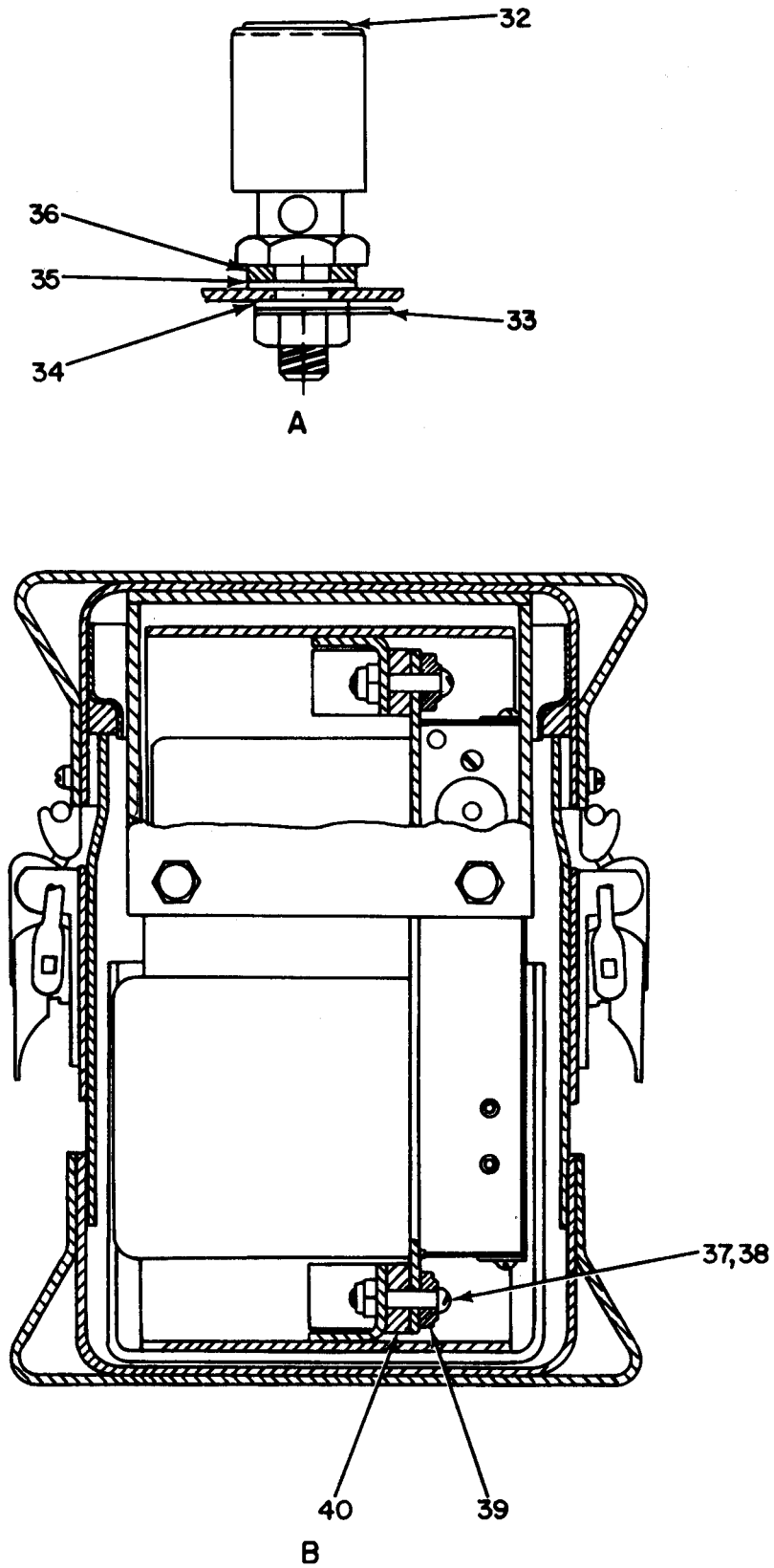

ELOIS023

Figure 17. Power Supply PP-990/G, (Sheet 3 of 3).

(1) ILLUSTRATION (a) FIG NO.	(2) (b) ITEM NO.	(3) SMR CODE	(4) NATIONAL STOCK NUMBER	(5) PART NUMBER	(6) FSCM	(7) DESCRIPTION USABLE ON CODE	(8) QTY INC IN UNIT
GROUP 05 POWER SUPPLY PP-990/G							
17	1	XDFZZ		SCD135948-1	80063	WASHER	EA 3
17	2	XDFZZ		SCD135948-2	80063	WASHER	EA 3
17	3	XDFZZ		104-25-4R	80063	WASHER	EA 3
17	4	XDFZZ		SMD199915-17	80063	LUG,NUMBER 20	EA 1
17	5	PAFZZ	5330-00-569-0313	SCB135952	80063	GASKET	EA 1
17	6	PAFZZ	6625-00-669-0748	SCB136010	80063	VOLTMETER	EA 1
17	7	XDOZZ		4131-25	75915	FUSE	EA 6
17	8	PAFZZ	5999-00-283-7177	SCB136007	80063	CAP,ELECTRICAL	EA 2
17	9	XDFZZ		ST42GLESSIONENUT	81349	SWITCH,TOGGLE	EA 1
17	10	XDFZZ		SCB136005	80063	PLATE,INSTRUCTION	EA 1
17	11	XDFZZ		ST42DLESSIONENUT	81349	SWITCH,TOGGLE	EA 1
17	12	PAOZZ	6240-00-223-9100	NE51	71744	LAMP,GLOW	EA 1
17	13	PAFZZ	6210-00-295-1797	SCB136009	80063	LENS,LIGHT	EA 1
17	14	XDFZZ		SCB136008	80063	SEAL NUT	EA 3
17	15	XDFZZ		ST52NLESSIONENOT	81349	SWITCH,TOGGLE	EA 1
17	16	XDFZZ		SCB136047	80063	CAPACITOR	EA 1
17	17	XDFZZ		SCB135954	80063	STANDOFF	EA 1
17	18	XDFZZ		SCD136013	80063	WIRING HARNESS	EA 1
17	19	PAFZZ	5325-00-520-1752	565	70485	GROMMET	EA 1
17	20	XDFZZ		SCD135948-14	80063	CLAMP,LOOP	EA 1
17	21	XDFFF		SCD135976	80063	CASE ASSEMBLY	EA 1
17	22	XDFZZ		SCD135948-16	80063	BOLT,MACHINE	EA 4
17	23	XDFFF		SCD136014	80063	INVERTER VIBRATOR	EA 1
17	24	XDFZZ		100-186-6	80063	SCREW,MACHINE	EA 1
17	25	XDFFF		SCD135955	80063	CHASSIS ASSEMBLY	EA 1
17	26	XDFZZ		SCD135948-13	80063	CLAMP,LOOP	EA 1
17	27	XDFZZ		SCB135955	80063	PLATE	EA 1
17	28	XDFZZ		102-35-6	80063	NUT	EA 1
17	29	XDFZZ		104-25-6R	80063	WASHER	EA 4
17	30	XDFZZ		104-15-6M	80063	WASHER	EA 2
17	31	XDFZZ		100-156-7	80063	SCREW,MACHINE	EA 2
17	32	XDFZZ		SCDL136437GR2	80063	SPRING BINDING POST	EA 8
17	33	PAFZZ	5940-00-518-7368	2168-14-00	78189	TERMINAL,LUG	EA 8
17	34	XDFZZ		SCD135948-3	80063	WASHER	EA 8
17	35	XDFZZ		SCD135948-12	80063	O RING	EA 8
17	36	XDFZZ		SCB135951	80063	BUSHING	EA 8
17	37	XDFZZ		100-2510-16	80063	SCREW,MACHINE	EA 4
17	38	XDFZZ		104-15-10L	80063	WASHER	EA 4
17	39	XDFZZ		SCB135950	80063	BUSHING	EA 4

(1)	(2)	(3)	(4)	(5)	(6)	(7)	(8)
ILLUSTRATION							QTY
(a)	(b)		NATIONAL				INC
FIG	ITEM	SMR	STOCK	PART			IN
NO.	NO.	CODE	NUMBER	NUMBER	FSCM	USABLE ON CODE	U\M UNIT
17	40	XDFZZ		SCB135949	80063		EA 2

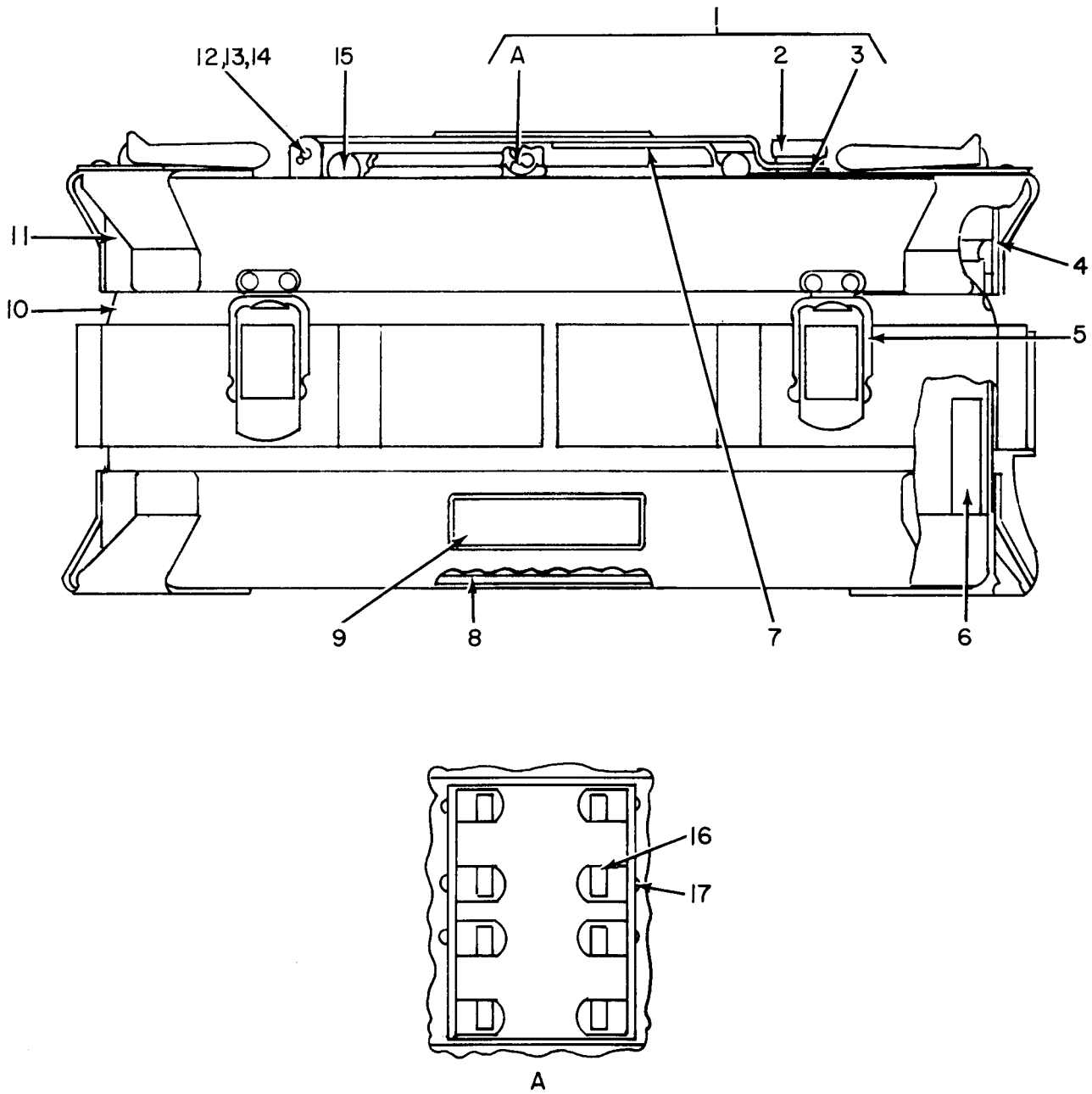

ELOIS024

Figure 18. Power Supply PP-990/G, Case Assembly.

(1)	(2)	(3)	(4)	(5)	(6)	(7)	(8)	
ILLUSTRATION							QTY	
(a)	(b)	NATIONAL			DESCRIPTION		INC	
FIG	ITEM	SMR	STOCK	PART			IN	
NO.	NO.	CODE	NUMBER	NUMBER	FSCM	USABLE ON CODE	U\M	
							UNIT	
18	1	XDFFF		SCC136000	80063	COVER ASSEMBLY	EA	1
18	2	XDFZZ		SCB136003	80063	KNOB	EA	1
18	3	ZSD		SCC136000-1	80063	WASHER	EA	1
18	4	PAFZZ	5330-00-395-9378	SCB135977	80063	GASKET	EA	1
18	5	PAFZZ	5340-00-200-8630	S1097	77893	CATCH, CLAMPING	EA	4
18	6	XDFZZ		SCD135976-3	80063	PAD	EA	4
18	7	XDFZZ		SCC135979	80063	CIRCUIT LABEL	EA	1
18	8	XDFZZ		SCD135976-2	80063	PAD	EA	1
18	9	XDFZZ		SCD135976-5	80063	PLATE, IDENT	EA	2
18	10	XDFZZ		SCD135980	80063	CASE ASSEMBLY	EA	1
18	11	XDFZZ		SCD135986	80063	COVER ASSEMBLY	EA	1
18	12	XDFZZ		SCB135978	80063	PIN	EA	1
18	13	XDFZZ		SCD135976-4	80063	WASHER	EA	2
18	14	XDFZZ		SCD135976-6	80063	PIN, COTTER .50 LONG	EA	2
18	15	XDFZZ		SCD135976-1	80063	GASKET	EA	1
18	16	PAFZZ	5940-00-279-8504	103001	75915	CLIP, ELECTRICAL	EA	8
18	17	XDFZZ		SE55	61957	EYELET	EA	8

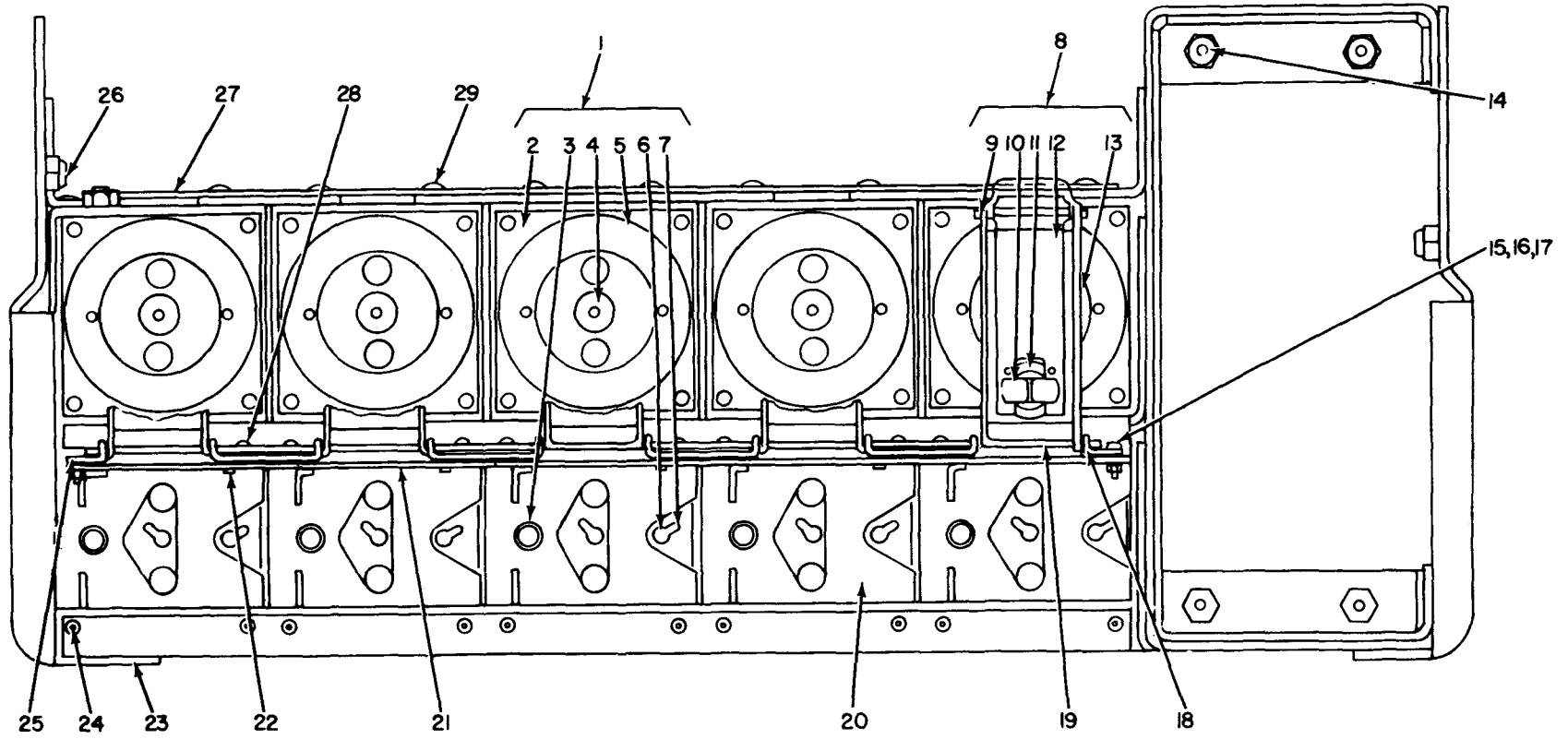

ELO15025

Figure 19. Power Supply PP-990/G, Chassis Assembly.

SECTION II

TM11-5805-304-24P

(1) ILLUSTRATION (a) FIG NO.	(2) ITEM NO.	(3) SMR CODE	(4) NATIONAL STOCK NUMBER	(5) PART NUMBER	(6) FSCM	(6) DESCRIPTION	(7) USABLE ON CODE	(8) QTY INC IN UNIT
19	1	XDFFF		SCB135961	80063	BATTERY CONT ASSY	EA	10
19	2	XDFZZ		SCB135962	80063	PLATE	EA	1
19	3	XDFZZ		MS15795-602	96906	WASHER, FLAT	EA	1
19	4	XDFZZ		SCB135961-1	80063	WASHER	EA	1
19	5	XDFZZ		SCB135963	80063	CONTACT	EA	1
19	6	PAFZZ	5325-00-275-4491	SE35	61957	EYELET	EA	3
19	7	XDFZZ		755	91886	TERMINAL, TINNED	EA	2
19	8	XDFFF		SCB135971	80063	DOOR ASSEMBLY	EA	10
19	9	XDFZZ		SCB135975	80063	PIN	EA	1
19	10	XDFZZ		SCB135974	80063	HOLDER	EA	1
19	11	PAFZZ	5310-00-809-8546	MS15795-208	96906	WASHER, FLAT	EA	1
19	12	XDFZZ		SCB135972	80063	PLATE	EA	1
19	13	XDFZZ		SCB135973	80063	DOOR	EA	1
19	14	XDFZZ		SCD135955-1	80063	NUT, CLINCH	EA	4
19	15	XDFZZ		SCD135955-8	80063	SCREW	EA	4
19	16	XDFZZ		SCD135955-7	80063	WASHER, LOCK	EA	4
19	17	XDFZZ		SCD135955-9	80063	NUT, HEXAGON	EA	4
19	18	XDFZZ		SCB135958-1	80063	BRACKET	EA	2
19	19	XDFZZ		SCB135960	80063	PIN	EA	2
19	20	XDFZZ		SCB135956	80063	BRACKET	EA	10
19	21	XDFZZ		SCB135959	80063	BRACKET	EA	8
19	22	XDFZZ		SCD135955-6	80063	RIVET .219 LONG	EA	20
19	23	XDFZZ		SCD135964	80063	BRACKET ASSEMBLY	EA	1
19	24	XDFZZ		SCD135955-3	80063	RIVET .281 LG	EA	40
19	25	XDFZZ		SCB135958-2	80063	BRACKET	EA	2
19	26	XDFZZ		SCD135955-2	80063	NUT, CLINCH	EA	4
19	27	XDFZZ		SCB135957	80063	PLATE	EA	2
19	28	XDFZZ		SCD135955-4	80063	RIVET .219 LONG	EA	40
19	29	XDFZZ		SCD135955-5	80063	RIVET .188 LONG	EA	20

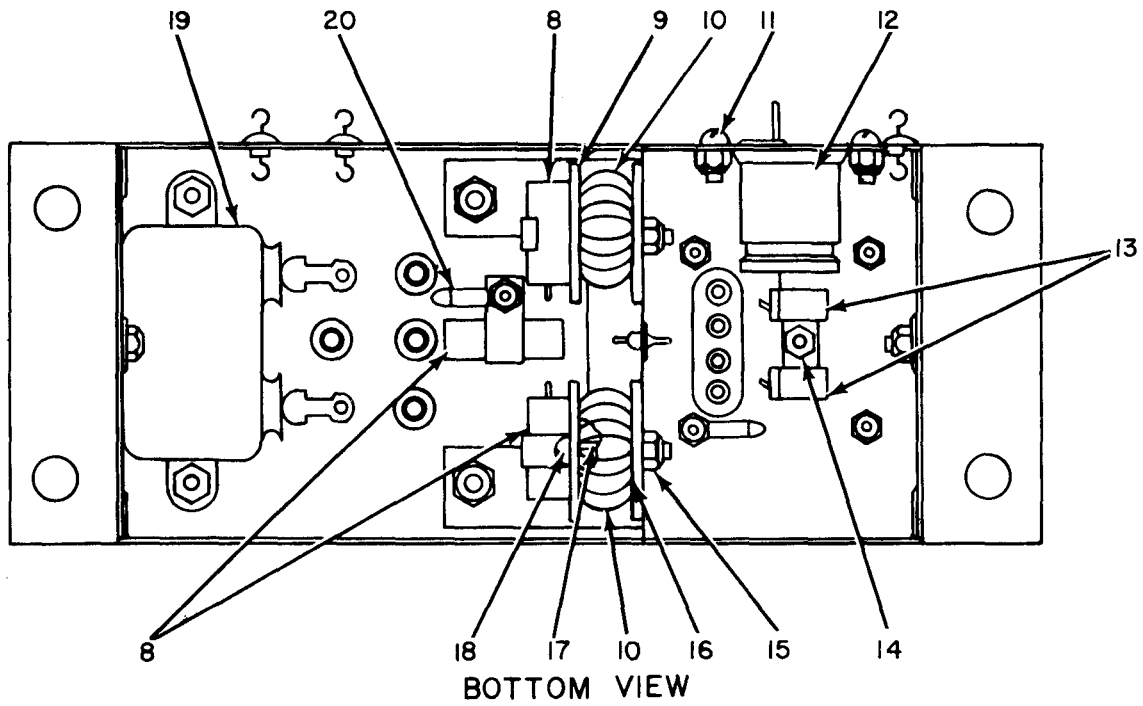
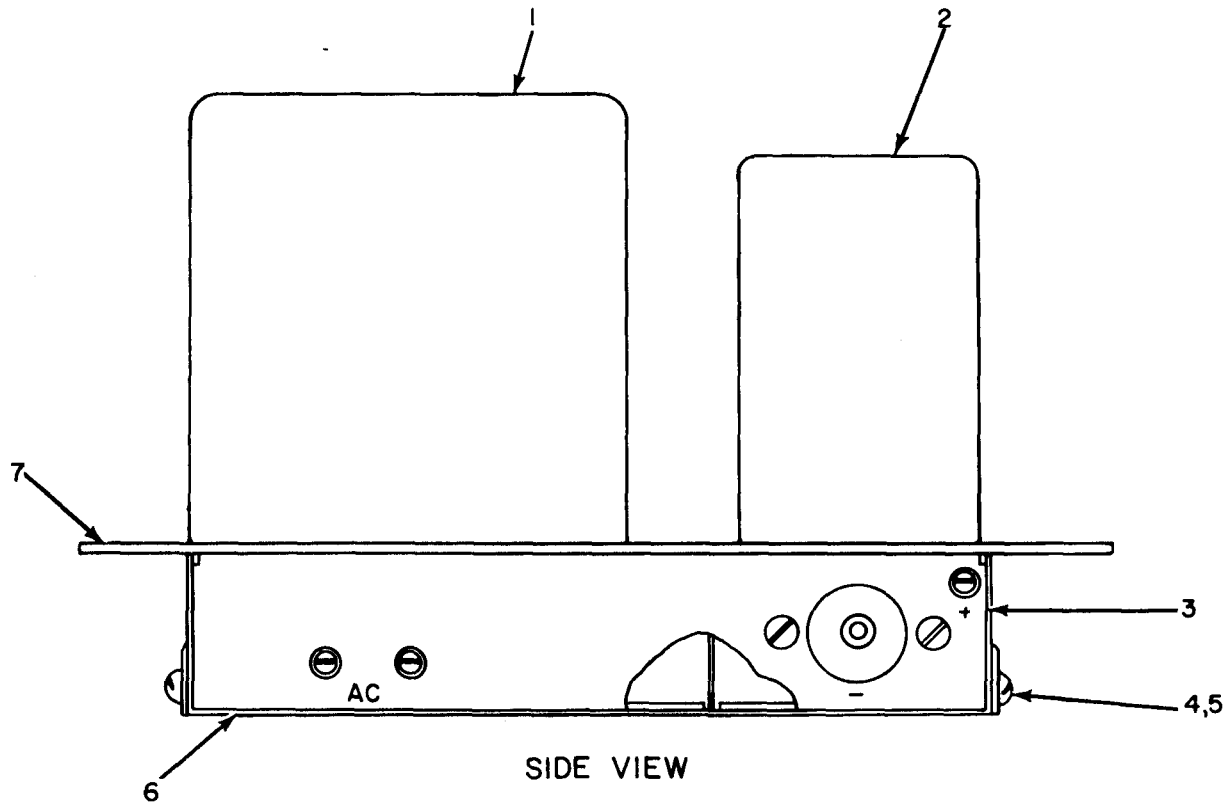

ELOIS026

Figure 20. Power Supply PP-990/G, Inverter Vibrator Assembly.

(1)	(2)	(3)	(4)	(5)	(6)	(7)	(8)	
ILLUSTRATION							QTY	
(a)	(b)	NATIONAL			DESCRIPTION		INC	
FIG	ITEM	SMR	STOCK	PART			IN	
NO.	NO.	CODE	NUMBER	NUMBER	FSCM	USABLE ON CODE	U/M	
							UNIT	
20	1	PAFZZ	5950-00-645-5449	SCD136032	80063	TRANSFORMER, POWER, V	EA	1
20	2	PAFZZ	6130-00-635-3503	SCB136024	80063	VIBRATOR, INTERRUPT	EA	1
20	3	XDFZZ		SCC136018	80063	BASE ASSEMBLY	EA	1
20	4	XDFZZ		100-154-6	80063	SCREW	EA	2
20	5	XDFZZ		104-35-4A	80063	WASHER, LOCK	EA	2
20	6	XDFZZ		SCB136016	80063	COVER ASSEMBLY	EA	1
20	7	XDFZZ		SCC136015	80063	BASE	EA	1
20	8	PAFZZ	5910-00-667-5215	SCB136044-2	80063	CAPACITOR, FIXED, PAP	EA	3
20	9	XDFZZ		SCD136014-1	80063	WASHER	EA	4
20	10	PAFZZ	5950-00-645-4227	SCB136022	80063	COIL, RADIO FREQUENC	EA	2
20	11	XDFZ		100-156-5	80063	SCREW	EA	2
20	12	PAFZZ	5910-00-667-5404	SCB136045	80063	CAPACITOR, FIXED, PAP	EA	1
20	13	PAFZZ	5910-00-284-4079	SCB136044-1	80063	CAPACITOR, FIXED, PAP	EA	2
20	14	XDFZZ		SCD136014-3	80063	BUSHING	EA	1
20	15	XDFZZ		102-35-6	80063	NUT	EA	6
20	16	XDFZZ		SCB136020	80063	BRACKET ASSEMBLY	EA	1
20	17	XDFZZ		SCD136014-2	80063	BUSHING	EA	2
20	18	XDFZZ		100-156-14	80063	SCREW	EA	2
20	19	XDFZZ		SCB136046	80063	CAPACITOR	EA	1
20	20	XDFZZ		4019-6	77147	TERMINAL	EA	3

NATIONAL STOCK NUMBER AND PART NUMBER INDEX

NOTE: LATEST NATIONAL STOCK NUMBER AND PART NUMBER ASSIGNMENTS ARE INCLUDED AT END OF INDEX

STOCK NUMBER	FIGURE NO.	ITEM NO.	STOCK NUMBER	FIGURE NO.	ITEM NO.
5310-00-012-0622	9	12	5805-00-392-7941	3	8
5310-00-012-0622	13	13	5805-00-392-7944	1	1
5310-00-012-0622	15	13	5805-00-392-7954	3	11
5310-00-013-4530	8	7	5805-00-392-7955	3	18
5305-00-043-6672	13	22	5805-00-392-8585	3	15
5310-00-045-3299	9	11	5935-00-393-1947	13	9
5310-00-045-3299	11	9	5935-00-393-1947	15	14
5310-00-045-3299	13	4	5330-00-395-9378	18	4
5310-00-045-3299	13	12	9905-00-396-3405	9	4
5310-00-045-3299	15	12	9905-00-396-3405	9	14
5310-00-045-3299	15	21	5340-00-396-3441	6	3
5930-00-050-2680	8	15	5340-00-396-3441	12	2
5930-00-050-2680	9	6	5305-00-416-6297	5	7
5930-00-050-2680	15	15	5805-00-503-3403	3	14
5805-00-096-7434	3	4	5940-00-518-7368	17	33
4820-00-142-3142	3	5	5995-00-537-5493	11	6
5360-00-159-0176	8	19	5930-00-548-5988	10	8
5310-00-167-0662	7	3	5935-00-549-2646	15	18
5905-00-190-8887	13	31	5930-00-549-7493	13	19
5905-00-190-8887	16	5	5330-00-569-0313	17	5
6240-00-196-4501	5	3	6130-00-635-3503	20	2
5310-00-198-3724	8	6	5310-00-638-6873	10	14
5330-00-198-6177	3	7	5940-00-643-5321	10	2
5315-00-200-8367	3	13	5950-00-645-4227	20	10
5340-00-200-8630	18	5	5950-00-645-4432	9	8
5935-00-201-8997	10	3	5950-00-645-4432	15	25
			5950-00-645-4464	15	26
5340-00-205-5206	3	1	5950-00-645-5449	20	1
6240-00-223-9100	17	12	5930-00-655-1513	9	3
5999-00-244-5150	8	26			
5325-00-275-4491	19	6	5910-00-667-5215	20	8
5905-00-279-2019	10	4	5910-00-667-5404	20	12
5905-00-279-2522	13	35	6625-00-669-0748	17	6
5940-00-279-8504	18	16	5805-00-670-5928	3	3
5325-00-281-1557	12	4	5310-00-680-6745	11	10
5325-00-281-1557	14	4	5310-00-685-3443	14	13
5999-00-283-7177	17	8	9905-00-806-1669	6	8
5910-00-284-4079	20	13	5805-00-806-1887	6	7
5920-00-284-9454	5	6	5310-00-809-8546	19	11
5920-00-284-9454	15	5	5310-00-820-0931	14	6
5920-00-285-0887	10	6	5310-00-840-6791	14	3
5920-00-285-0887	13	37	5805-00-875-1253	1	4
5920-00-285-0887	16	3	5305-00-882-4055	13	6
5325-00-285-2017	6	6	5305-00-882-4055	15	6
5325-00-285-2017	12	8	5305-00-883-8377	13	3
6210-00-295-1797	17	13	5305-00-883-8377	15	20
5930-00-324-9119	14	11	5305-00-889-3000	9	18
6140-00-333-9737	15	23	5305-00-889-3001	8	5
6350-00-351-8022	9	15	5805-00-926-3226	10	1
5330-00-392-5792	6	13	5805-00-926-3226	13	28
5330-00-392-5793	12	9	5305-00-988-1167	14	2
5940-00-392-7936	11	2			

PART NUMBER	FSCM	FIG. NO.	ITEM NO.	PART NUMBER	FSCM	FIG. NO.	ITEM NO.
AN931-10-14	88044	12	4				
AN931-10-14	88044	14	4				
CP27A1EC504K1	81349	15	32				
H-91/U	80058	1	5				
MS15795	96906	11	10				
				MS35226-64	96906	5	7
MS15795-208	96906	19	11	MS35241-50	96906	9	9
MS15795-602	96906	19	3				
MS35058-9	96906	8	15	MS35333-93	96906	8	10
MS35058-9	96906	9	6	MS35333-97	96906	10	14
MS35058-9	96906	15	15				
				MS35337-41	96906	8	6
				MS35337-42	96906	9	11
MS35225-27	96906	13	16	MS35337-42	96906	11	9
MS35225-27	96906	15	24	MS35337-42	96906	13	4
				MS35337-42	96906	13	12
MS35225-30	96906	9	18	MS35337-42	96906	15	12
MS35225-31	96906	8	5	MS35337-42	96906	15	21
MS35225-37	96906	13	22	MS35337-43	96906	7	3
MS35225-4	96906	14	2	MS35337-98	96906	8	3

NATIONAL STOCK NUMBER AND PART NUMBER INDEX

PART NUMBER	FSCM	FIG. NO.	ITEM NO.	PART NUMBER	FSCM	FIG. NO.	ITEM NO.
MS35649-104	96906	8	16	SCB136204	80063	15	22
				SCB136206	80063	13	25
MS35649-62	96906	8	7	SCB136206	80063	15	29
MS35649-64	96906	8	2	SCB136219	80063	13	9
MS35649-82	96906	9	12	SCB136219	80063	15	14
MS35649-82	96906	13	13	SCB136222	80063	13	6
MS35649-82	96906	15	13	SCB136222	80063	15	6
				SCB136223	80063	13	3
NE51	71744	17	12	SCB136223	80063	15	20
				SCB136227-1	80063	13	24
PP-990/G	80058	1	3	SCB136227-3	80063	15	30
P123ZMB2MP	00656	15	37	SCB136228	80063	13	33
P123ZN	00656	13	21	SCB136229	80063	13	36
P123ZN	00656	15	27	SCB136230	80063	13	34
P519	91816	3	5	SCB136234	80063	14	7
				SCB136235	80063	14	6
				SCB136236	80063	14	8
RC20GF154J	81349	13	35	SCB136237	80063	14	5
RC20GF202J	81349	13	31	SCB136242	80063	14	12
RC20GF202J	81349	16	5	SCB136284-1	80063	8	17
RC20GF512J	81349	10	4	SCB136284-1	80063	15	2
SB-248/P	80058	1	2	SCB136298	80063	8	20
SCB136435	80063	8	1	SCB136299	80063	8	21
SCB135949	80063	17	40	SCB136300	80063	8	4
SCB135950	80063	17	39	SCB136301	80063	8	8
SCB135951	80063	17	36	SCB136302	80063	8	19
SCB135952	80063	17	5	SCB136303	80063	8	12
SCB135954	80063	17	17	SCB136303	80063	15	3
SCB135955	80063	17	27	SCB136305	80063	15	34
SCB135956	80063	19	20	SCB136306	80063	9	8
SCB135957	80063	19	27	SCB136306	80063	15	25
SCB135958-1	80063	19	18	SCB136325	80063	13	29
SCB135958-2	80063	19	25	SCB136326	80063	13	30
SCB135959	80063	19	21	SCB136328	80063	13	26
SCB135960	80063	19	19	SCB136329	80063	13	27
SCB135961	80063	19	1	SCB136331	80063	13	2
SCB135961-1	80063	19	4	SCB136331	80063	15	19
SCB135962	80063	19	2	SCB136336	80063	16	4
SCB135963	80063	19	5	SCB136337	80063	16	1
SCB135971	80063	19	8	SCB136342	80063	13	18
SCB135972	80063	19	12	SCB136403	80063	6	10
SCB135973	80063	19	13	SCB136404	80063	6	13
SCB135974	80063	19	10	SCB136410	80063	6	4
SCB135975	80063	19	9	SCB136411	80063	6	3
SCB135977	80063	18	4	SCB136411	80063	12	2
SCB135978	80063	18	12	SCB136413	80063	6	9
SCB136003	80063	18	2	SCB136428	80063	7	5
SCB136005	80063	17	10	SCB136431	80063	8	22
SCB136006	80063	17	14	SCB136432	80063	8	24
SCB136007	80063	17	8	SCB136433	80063	8	23
SCB136009	80063	17	13	SCB136434	80063	8	14
SCB136010	80063	17	6	SCB136445	80063	9	16
SCB136016	80063	20	6	SCB136446	80063	9	17
SCB136020	80063	20	16	SCB136456	80063	10	15
SCB136022	80063	20	10	SCB136484	80063	10	7
SCB136024	80063	20	2	SCB136485	80063	10	2
SCB136044-1	80063	20	13	SCB136550	80063	9	15
SCB136044-2	80063	20	8	SCB136553	80063	8	11
SCB136045	80063	20	12	SCB136555	80063	10	6
SCB136046	80063	20	19	SCB136555	80063	13	37
SCB136047	80063	17	16	SCB136555	80063	16	3
SCB136103-2	80063	3	16	SCB136556	80063	10	5
SCB136104	80063	3	13	SCB136556	80063	13	32
SCB136105	80063	3	15	SCB136556	80063	16	2
SCB136106	80063	3	18	SCB136557	80063	9	7
SCB136107	80063	3	11	SCB136563	80063	6	2
SCB136108	80063	3	10	SCB136602	80063	11	5
SCB136109	80063	3	8	SCB136603	80063	11	6
SCB136111	80063	3	6	SCB136605	80063	12	9
SCB136112	80063	3	2	SCB136606	80063	12	10
SCB136113	80063	3	1	SCB136628	80063	11	2
SCB136138	80063	4	5	SCC135979	80063	18	7
SCB136139	80063	4	2	SCC136000	80063	18	1
SCB136142	80063	2	3	SCC136000-1	80063	18	3
SCB136143	80063	2	4	SCC136015	80063	20	7
SCB136144	80063	2	2	SCC136018	80063	20	3
SCB136146	80063	3	4	SCC136132	80063	3	14
SCB136148	80063	4	3	SCC136136	80063	3	3
SCB136202	80063	13	8	SCC136136-1	80063	4	4
SCB136202	80063	15	9	SCC136136-2	80063	4	6

NATIONAL STOCK NUMBER AND PART NUMBER INDEX

PART NUMBER	FIG. FSCM NO.	ITEM NO.	PART NUMBER	FIG. FSCM NO.	ITEM NO.
SCC136137	80063	4	1	SCD136402	80063 5 1
SCC136140	80063	1	1	SCD136402-2	80063 6 11
SCC136141	80063	2	1	SCD136402-3	80063 6 12
SCC136239	80063	14	1	SCD136405	80063 6 1
SCC136246	80063	14	11	SCD136424	80063 5 8
SCC136295	80063	15	23	SCD136427	80063 5 2
SCC136335	80063	15	28	SCD136429	80063 7 1
SCC136412	80063	6	5	SCD136430	80063 8 27
SCC136414	80063	6	7	SCD136439	80063 8 28
SCC136415	80063	6	8	SCD136444	80063 7 4
SCC136420	80063	5	5	SCD136455	80063 9 5
SCC136447	80063	9	14	SCD136548	80063 9 1
SCC136448	80063	9	4	SCD136604	80063 11 7
SCC136457	80063	10	3	SCD136618	80063 12 1
				SCD136626	80063 11 1
SCC136483	80063	10	1	SCD18034	80063 15 17
SCC136483	80063	13	28	SCD83050	80063 15 18
SCC136487	80063	10	8	SE35	61957 19 6
SCC136508GRP1	80063	13	20	SE55	61957 18 17
SCC136508GRP2	80063	9	13	SMD199915-17	80063 17 4
SCC136609	80063	12	3	ST42DLESSONENUT	81349 17 11
SCC136611-1	80063	12	7	ST42E	04009 9 3
SCC136616	80063	12	6	ST42GLESSIONENUT	81349 17 9
SCC48305,GRP1	80063	14	9	ST52NLESSONENUT	81349 17 15
SCC84553	80063	15	16	S1097	77893 18 5
SCC84598	80063	15	26		
SCDL136437GRP3	80063	8	18		
SCDL136437GRP3	80063	15	1		
SCDL136437GR2	80063	17	32	100-154-6	80063 20 4
SCD135948-1	80063	17	1	100-156-14	80063 20 18
SCD135948-12	80063	17	35	100-156-5	80063 20 11
SCD135948-13	80063	17	26	100-156-7	80063 17 31
SCD135948-14	80063	17	20	100-186-6	80063 17 24
SCD135948-16	80063	17	22	100-2510-16	80063 17 37
SCD135948-2	80063	17	2	100-785-6	80063 14 14
SCD135948-3	80063	17	34	102-35-6	80063 17 28
SCD135955	80063	17	25	102-35-6	80063 20 15
SCD135955-1	80063	19	14	103001	75915 18 16
SCD135955-2	80063	19	26	104-15-10L	80063 17 38
SCD135955-3	80063	19	24	104-15-6M	80063 17 30
SCD135955-4	80063	19	28	104-25-4R	80063 17 3
SCD135955-5	80063	19	29	104-25-6R	80063 17 29
SCD135955-6	80063	19	22	104-35-4A	80063 20 5
SCD135955-7	80063	19	16	1490	24446 5 3
SCD135955-8	80063	19	15	1681	72765 9 2
SCD135955-9	80063	19	17	1820-21	81168 3 7
SCD135964	80063	19	23	209	74310 3 12
SCD135976	80063	17	21	2168-14-00	78189 17 33
SCD135976-1	80063	18	15	2600-1	71286 6 6
SCD135976-2	80063	18	8	2600-1	71286 12 8
SCD135976-3	80063	18	6	3-5-16	95987 11 8
SCD135976-4	80063	18	13		
SCD135976-5	80063	18	9	3131-25	60016 5 6
SCD135976-6	80063	18	14	3131-25	60016 15 5
SCD135980	80063	18	10	4019-6	77147 20 20
SCD135986	80063	18	11	41-27J	71688 8 9
SCD136013	80063	17	18	4131-25	75915 17 7
SCD136014	80063	17	23	5133-31	79136 13 5
SCD136014-1	80063	20	9	5133-31	79136 15 7
SCD136014-2	80063	20	17	565	70485 17 19
SCD136014-3	80063	20	14		
SCD136032	80063	20	1	68NM26	72962 14 13
SCD136102	80063	1	4	68NM50	72962 14 3
SCD136102-6	80063	3	9	68NM62	72962 9 19
SCD136102-7	80063	3	17	68NM62	72962 13 17
SCD136201-7	80063	13	7	68NM62	72962 13 23
SCD136201-7	80063	15	8	68NM62	72962 15 31
SCD136207	80063	13	1	68NM62	72962 15 36
SCD136313	80063	13	15	702	71286 5 9
				755	91886 19 7
SCD136320	80063	13	19	9435-1-2	71400 8 26
SCD136401-8	80063	5	4		

SECTION IV
 NATIONAL STOCK NUMBER AND PART NUMBER INDEX

TM11-5805-304-24P

STOCK NUMBER	FIGURE NO.	ITEM NO.	STOCK NUMBER	FIGURE NO.	ITEM NO.
5305-00-043-5885	13	16	5310-00-809-8544	13	11
5305-00-043-5885	15	24	5310-00-809-8544	15	11
5930-00-259-7528	15	16	5935-00-837-5969	14	10
5805-00-356-2738	11	3	5310-00-934-9748	10	11
5805-00-503-2616	1	6	5305-00-984-6193	13	10
5805-00-503-3343	11	4	5305-00-984-6193	15	10
5325-00-520-1752	17	19	5305-00-984-6222	16	6
5910-00-681-9093	13	21	5305-00-993-0190	10	10
5910-00-681-9093	15	27	5305-00-993-0190	16	7
5310-00-809-8544	9	10			

LATEST NATIONAL PART NUMBER INDEX

PART NUMBER	FSCM	FIG. NO.	ITEM NO.	PART NUMBER	FSCM	FIG. NO.	ITEM NO.
				MS35206-245	96906	15	10
				PJ-051R	81349	14	10
				TA207P	80058	1	6
				TA208P	80058	11	4
MS35206-245	96906	13	10	TA220P	80058	11	3

ADDITIONAL LATEST NATIONAL STOCK NUMBER ASSIGNMENTS ADDITIONAL LATEST PART NUMBER ASSIGNMENTS

STOCK NUMBER	FIG. NO.	ITEM NO.	PART NUMBER	FSCM	FIG. NO.	ITEM NO.
5905-00-110-0196	10	12	HKPZEQ	71400	8	25
5905-00-279-3511	10	9	HKPZEQ	71400	15	4
6130-00-547-1030	1	3	MS27183-7	96906	9	10
5305-00-889-2997	10	13	MS27183-7	96906	13	11
5305-00-889-3002	11	11	MS27183-7	96906	15	11
5920-00-892-9311	8	25	MS35190-222	96906	15	33
5920-00-892-9311	15	4	MS35191-272	96906	7	2
5310-00-934-9739	16	9	MS35206-214	96906	10	13
5305-00-984-4989	15	38	MS35206-214	96906	16	7
5305-00-984-4989	15	35	MS35206-214	96906	16	7
5305-00-984-6196	8	13	MS35206-226	96906	15	38
5305-00-984-7363	7	2	MS35206-229	96906	15	35
5305-00-995-6653	15	33	MS35206-235	96906	16	6
			MS35206-242	96906	11	11
			MS35206-248	96906	8	13
			MS35333-29	96906	16	8
			MS35649-242	96906	16	9
			MS35649-244	96906	10	11
			RCR20G102JS	81349	10	12
			RC20GF511J	81349	10	9
			SCC136611	80063	12	5
			SCD136232	80063	13	14
			68NM62	72962	15	39



SOMETHING WRONG WITH THIS MANUAL?

THEN... JOT DOWN THE DOPE ABOUT IT ON THIS FORM, TEAR IT OUT, FOLD IT AND DROP IT IN THE MAIL!

FROM: (YOUR UNIT'S COMPLETE ADDRESS)

Commander
Stateside Army Depot
ATTN: AMSTA-US
Stateside, N.J. 07703

DATE 10 July 1975

PUBLICATION NUMBER TM 11-5840-340-20P	DATE 23 Jan 78	TITLE Radar Set AN/PRC-76
--	-------------------	------------------------------

BE EXACT... PIN-POINT WHERE IT IS				IN THIS SPACE TELL WHAT IS WRONG AND WHAT SHOULD BE DONE ABOUT IT:
PAGE NO.	PARA-GRAPH	FIGURE NO.	TABLE NO.	
33				For item 2, change the NSN to read: 5835-00-134-9186. <u>Reason:</u> Accuracy.
44		19		Identify the cover on the junction box (item no. 5). <u>Reason:</u> It is a separate item and is not called out on figure 19.
45				Add the cover of the junction box as an item in the listing for figure 19. <u>Reason:</u> Same as above.

TEAR ALONG DOTTED LINE

S
A
M
E

TYPED NAME, GRADE OR TITLE, AND TELEPHONE NUMBER SSG I. M. DeSpiritof 999-1776	SIGN HERE: <i>SSG I. M. DeSpiritof</i>
---	---

FILL IN YOUR
UNIT'S ADDRESS

FOLD BACK

DEPARTMENT OF THE ARMY

OFFICIAL BUSINESS

Commander
US Army Communications and
Electronics Materiel Readiness Command
ATTN: DRSEL-ME-MQ
Fort Monmouth, New Jersey 07703

FOLD BACK

TEAR ALONG DOTTED LINE

FILL IN YOUR
UNIT'S ADDRESS

FOLD BACK

DEPARTMENT OF THE ARMY

OFFICIAL BUSINESS

Commander
US Army Communications and
Electronics Materiel Readiness Command
ATTN: DRSEL-ME-MQ
Fort Monmouth, New Jersey 07703

FOLD BACK

TEAR ALONG DOTTED LINE

RECOMMENDED CHANGES TO EQUIPMENT TECHNICAL MANUALS



SOMETHING WRONG WITH THIS MANUAL?

THEN... JOT DOWN THE DOPE ABOUT IT ON THIS FORM, TEAR IT OUT, FOLD IT AND DROP IT IN THE MAIL!

FROM: (YOUR UNIT'S COMPLETE ADDRESS)

DATE

PUBLICATION NUMBER

TM 11-5805-304-24P

DATE

21 Aug 80

TITLE

Manual Telephone Switchboard SB-86/P

BE EXACT... PIN-POINT WHERE IT IS

PAGE NO.

PARA-GRAPH

FIGURE NO.

TABLE NO.

IN THIS SPACE TELL WHAT IS WRONG AND WHAT SHOULD BE DONE ABOUT IT:

TEAR ALONG DOTTED LINE

TYPED NAME, GRADE OR TITLE, AND TELEPHONE NUMBER

SIGN HERE:

DA FORM 2028-2
1 AUG 74

P.S.--IF YOUR OUTFIT WANTS TO KNOW ABOUT YOUR MANUAL "FIND," MAKE A CARBON COPY OF THIS AND GIVE IT TO YOUR HEADQUARTERS.

FILL IN YOUR
UNIT'S ADDRESS

FOLD BACK

DEPARTMENT OF THE ARMY

OFFICIAL BUSINESS

Commander
US Army Communications and
Electronics Materiel Readiness Command
ATTN: DRSEL-ME-MQ
Fort Monmouth, New Jersey 07703

FOLD BACK

TEAR ALONG DOTTED LINE

By Order of the Secretary of the Army:

E. C. MEYER
General, United States Army
Chief of Staff

Official:

J. C. PENNINGTON
Major General, United States Army
The Adjutant General

DISTRIBUTION:

<i>Active Army:</i>	6-701
HISA (Ft Monmouth) (21)	7
USAINSCOM (2)	7-15
COE (1)	7-16
TSG (1)	7-35
USAARENBD (1)	7-36
DARCOM (1)	8-112
TRADOC (2)	8-137
OS Maj Comd (4)	8-551
TECOM (2)	8-566
USACC (4)	9-22
MDW (1)	10-206
Armies (2)	11-95
Corps (2)	11-96
Svc Colleges (1)	11-87
USASIGS (5)	11-117
USAADS (2)	11-122
USAFAS (2)	11-215
USAARMS (2)	11-217
USAIS (2)	11-218
USAES (2)	11-237
USAICS (3)	11-302
MAAG (1)	11-500(AA-AC)
USARMIS (1)	17
USAERDAA (1)	17-51
USAERDAW (1)	17-52
Ft Gordon (10)	19-262
Ft Carson (5)	29-51
Army Dep (1) except	29-106
SAAD (30)	29-134
TOAD (14)	29-136
SHAD (2)	29-245
Ft Gillem (10)	29-246
USA Dep (1)	30-25
Sig Sec USA Dep (1)	30-29
Ft Richardson (CERCOM Ofc) (2)	33-500
Units org under fol TOE:	37
(2 cys each unit)	39-51
29-207	44-2
29-610	44-12
(1 cy each unit)	55-4
5-52	55-11
5-101	55-12
5-111	55-62
5-112	55-201
6-100	55-202
6-200	55-225
6-201	55-226
6-302	55-227
6-401	57
6-501	57-42
6-502	57-100
6-615	57-102
6-616	77-100
6-700	77-102

NG: State AG (3): Units—Same as Active Army except allowance is one (1) copy per unit.

USAR: None

For explanation of abbreviations used, see AR 310-50.

